

THE MAGAZINE FOR CONSUMER ELECTRONICS SERVICING PROFESSIONALS

# ELECTRONIC<sup>TM</sup>

Servicing & Technology

OCTOBER 1989/\$3.00

*1  
SIMPLE TRANSISTOR  
AMP. DESIGN*

Focus on facsimile • Product preview

Servicing Zenith microcomputers — Part IV



Basic  
CD player  
servicing  
techniques

AN INTEREC PUBLICATION

[www.americanradiohistory.com](http://www.americanradiohistory.com)

# Cut Your Video Troubleshooting Time By 54%\* With The VA62A Universal NTSC Video Analyzing System

**New  
And Improved!**



**VA62A Universal Video Analyzer**  
*Patented*

- Identify tuner problems with All-Channel, VHF, UHF, and Cable RF Generators.
- Pinpoint IF Problems with modulated troubleshooting signal and exclusive programmable IF/RF generators.
- Isolate any video problems with patented video and standard color-bar patterns.
- Find defective stages, without disconnecting parts, using exclusive phase-locked drive signals.
- Test yokes and flybacks, plus measure signal levels with autoranged digital meter.

\* Based on a nationwide survey of users who reported an average time savings of 54% compared to their previous test equipment.

**Call 1-800-SENCORE**  
*(736-2673)*  
In Canada 1-800-851-8866

## Update For New Technology With Exclusive Phase-Locked Accessories

### VC63 VCR Test Accessory

Solve the VCR servicing challenge with substitute VCR signals, phase-locked to your VA62A.



### NT64 NTSC Pattern Generator

Meet all Warranty Requirements by adding the NTSC full-field and split-field patterns to your VA62A Universal Video Analyzer.



### ST65 Video Analyzer Stereo TV Adder

Easily test and troubleshoot today's new MTS Stereo TVs & VCRs.



### RG67 NTSC Video Monitor Adaptor

Expand into analog and digital video monitor service with phase-locked R, G, B and I signals.



**SENCORE**

Circle (1) on Reply Card

# SPIKES, SAGS & SURGES

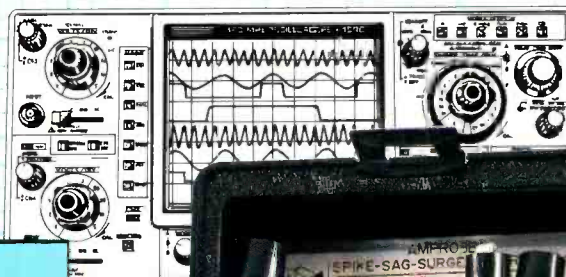
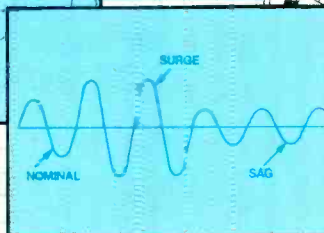
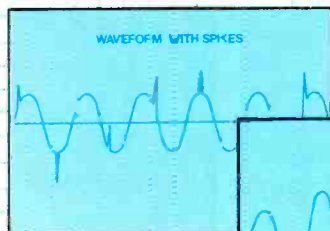

You need a tool to identify these disturbances before they cause a problem.

You need our new line disturbance recorder:

## AMPROBE® SPIKE-SAG-SURGE RECORDER

- Solid State Circuit Design
- Easy to use, affordable
- All 3 disturbances appear on same chart
- Low Battery Indication

Ranges are 220/440/880V full scale.  
User adjustable threshold.

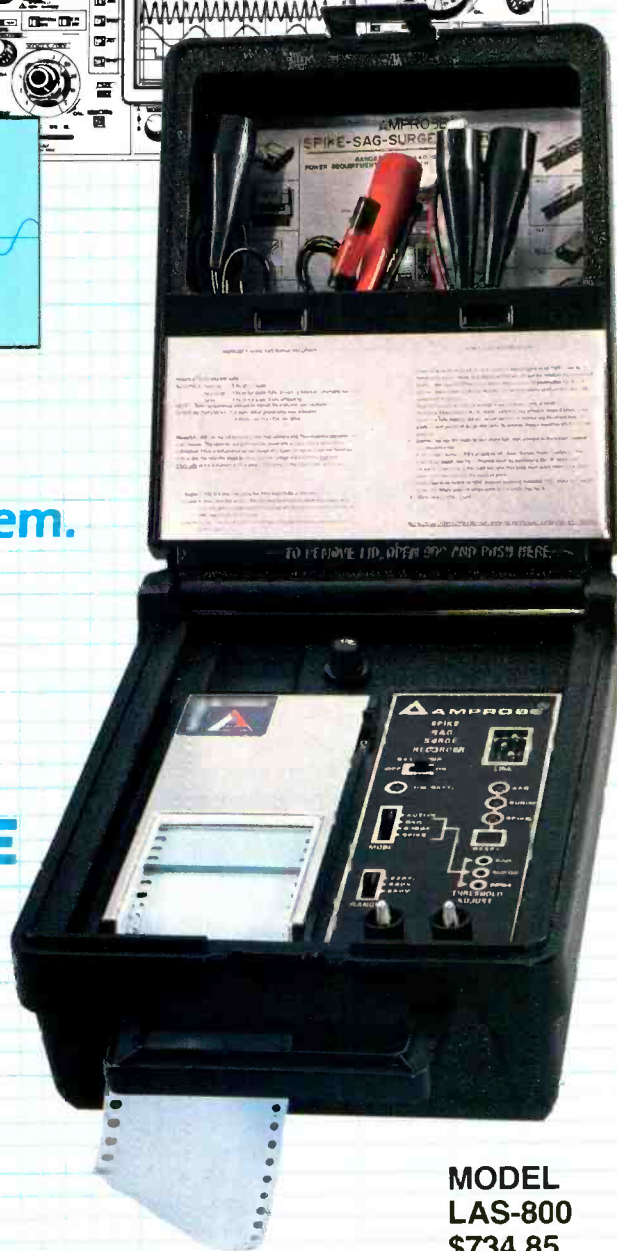

MODEL  
LAS-800  
\$734.85

Available in well over 100 countries around the world.



Write for Catalog AAD-86 or visit your Amprobe distributor today.

Circle (3) on Reply Card



Page 10

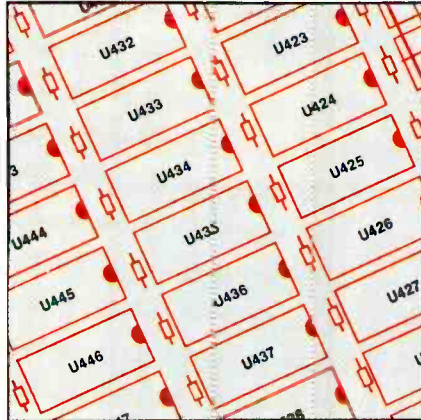

Page 20

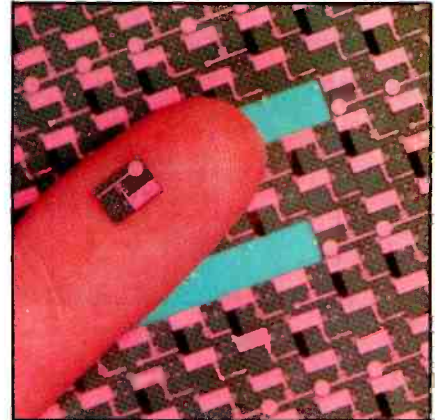

Page 56

## FEATURES

### 10 Basic Compact-Disc Player Servicing Techniques

By Homer L. Davidson

The days of the turntable are numbered. With CD's high-fidelity, broad dynamic range and simplicity of use, many audiophiles are turning to the CD and away from the phonograph record. It's no wonder records are becoming hard to come by. But non-functional CD players aren't particularly hard to find, and they should become more plentiful in the future. For some electronics servicers, that means business opportunity.

### 20 Servicing Zenith Microcomputers Part IV: Semiconductor Memory Devices

By John A. Ross

When you hear the word computer, you might think of those banks of mainframes that keep the world running these days, but for most of us, the computer is just a nice, safe place to store the things we'd rather not forget. Here's Part IV of the series — the anatomy of computer memory.

### 40 Focus on Facsimile

By Roger McCarty

Have you ever tried to get an

important call in to someone, only to be stymied by an ever-ringing telephone or a botched message? Or, even worse, you have an important document you want someone to see, but you don't want to trust it to the mail or even out of your hands. Two scenarios, two examples of why fax machines are becoming so popular. If you're interested in exploring this new servicing field, here are some tools to get you started.

## ADVERTISING SUPPLEMENT

### 44 Product Preview

## DEPARTMENTS

### 4 Editorial

Have you considered CD servicing?

### 6 News

### 8 Test Your Electronics Knowledge

### 18 Syncure

### 19 Literature

### 24 Feedback

### 27 Profax

### 38 Books

### 46 What Do You Know About Electronics?

The turbo tweaker

### 49 Troubleshooting Tips

### 50 Audio Corner

Keeping the CD laser pickup in focus

### 52 Computer Corner

Setting up a personal computer

### 54 Video Corner

Understanding the VCR vacuum-fluorescent display — Part I

### 56 Technology

Miniaturizing the IC

### 58 Business Corner

The basics of Yellow Page advertising

### 59 Readers' Exchange

### 60 Advertisers' Index

## ON THE COVER

The compact disc is becoming the audio medium of choice for many dedicated listeners — industry experts expect 6.5 million CD players to be sold this year. CD servicing is, therefore, becoming the servicing niche of choice for many servicing professionals. However, because only about 15% of U.S. households own CD players, servicing skills learned today should be in even greater demand in the future.

THE MAGAZINE FOR CONSUMER ELECTRONICS SERVICING PROFESSIONALS

**ELECTRONIC**  
Servicing & Technology

“A Teacher Affects Eternity;  
He Can Never Tell Where  
His Influence Stops.”

—Henry Brooks Adams

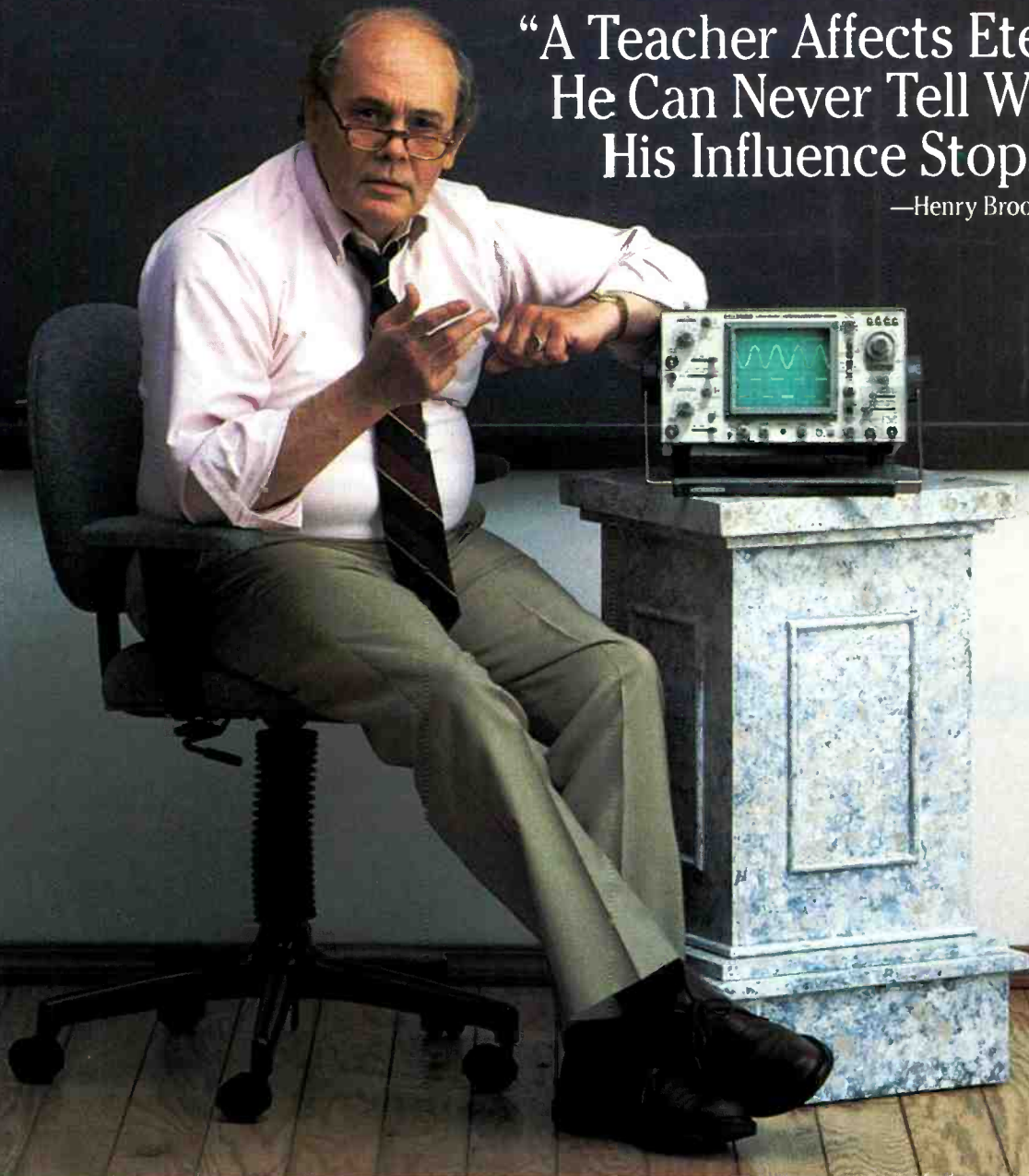

## LET LEADER BE INSTRUMENTAL IN THE LEARNING PROCESS

Henry Adams' quote captures a wonderful sentiment. Of course, in Mr. Adams' time, a teacher needed to concern himself with little more than the three R's. Today, teachers of electronic theory and technology require the sophisticated instruments that will prepare their students for work in the next century.

We can help you meet this important obligation by offering a broad range of test equipment for classroom applications. This includes oscilloscopes, function generators, power supplies, and more. Your students will appreciate the valuable experience they gain from training on Leader equipment. They'll find Leader's leading-edge instruments used extensively in R&D, production, industrial, and service facilities.

For reliable performance and

durability, Leader is unparalleled, maintaining a remarkable rate of *less than 1%* return during the 2-year warranty period. This high degree of dependability eliminates the inconvenience caused by equipment that spends more time in the repair shop than in your classroom.

For full-line coverage, absolute precision, and prices that won't tug at your purse strings, go with Leader.

The reliability of our products lets you get on with the business of education. For our full-line catalog, in NY call 516 231-6900. Or call toll-free:

**1 800 645-5104**

**LEADER**  
FOR PROFESSIONALS WHO KNOW  
THE DIFFERENCE



Leader Instruments Corporation, 380 Oser Avenue, Hauppauge, New York 11788  
Regional Offices: Chicago, Dallas, Los Angeles, Boston, Atlanta. In Canada call Omnitronix Ltd., 416 828-6221.

For Information Circle (4) on Reply Card  
For Demonstration Circle (5) on Reply Card

[www.americanradiohistory.com](http://www.americanradiohistory.com)

# Have you considered CD servicing?

CD seems to have taken over as the technology of choice for audio recording and playback. Although the consumer can't use it to record, its outstanding fidelity, broad dynamic range, resistance to damage and simplicity of use makes it a popular medium.

CD also seems to be the technology of choice for storing large amounts of computer data. Available now are CD-ROM disks and drives for use with personal computers such as IBM and compatibles. The abbreviation CD-ROM stands for compact disc — read only memory.

CD-ROM discs have the same disadvantage as music CDs: They are manufactured with the information on them (computer programs, data) and are then played back. They cannot be erased and written to by the computer operator as can magnetic discs, floppy or rigid.

The important advantage is that they are capable of holding huge amounts of data — in the area of 600 million bytes. One of the earliest demonstrations of this data density was the storage of an entire encyclopedia on a single disk. Another example of this technology is the Microsoft Bookshelf. This disc packs a number of reference books onto one disk.

Many other things are happening now that can be expected to further fuel the development of CD-ROM. There is now a portable reader so that a reference on CD-ROM can be read anywhere — you don't have to be at a computer. In fact, this reader is a computer without a keyboard. There is a place to plug in a key-

board, which will turn it into an 80286 computer. (The product is relatively expensive at \$5,000.)

In addition to the existing CD-ROM technology, manufacturers are working on a number of enhancements that will make it even more attractive. It may be possible for consumers to buy a CD-ROM with, say, an encyclopedia with dictionary that will contain not only text but pictures and voice (for correct pronunciation, for example).

Another CD technology that is available now, although extremely expensive, is a unit that will provide not only animation but real-motion video that is similar to the output of a TV or VCR.

I was told recently that if you go out to buy a music system these days, the system will almost certainly include a CD, but if you want a standard turntable you might have to place a special order. Apparently the CD has now become the standard source for recorded music. The CD-ROM, which is similar in construction, is becoming an important input for computers.

It sounds as though these devices will probably be around for a long time. These units are complex and will need to be serviced. If you enjoy Homer Davidson's articles on TV servicing, take a look at his article in this issue, "Basic Compact-Disc Player Servicing Techniques," a primer on servicing CDs. For anyone thinking about trying out this new servicing venture, it would be worthwhile reading.

*Nile Conrad Pearson*

**FLUKE**



**PHILIPS**



# Great Choice.

**More professionals in more industries make Fluke their first choice in multimeters.**

Fluke DMMs. Reliable. Accurate. Powerful. Tough. Versatile. Easy to use and simple to operate. Backed by the longest, most comprehensive warranty in the business. Made in the U.S.A. In short, Fluke makes meters you can bet your reputation on.

**More choice.** No matter what the job, there's a Fluke to handle it.

There's the new 80 Series—the most powerful, most complete test and measurement system available in a handheld package.

The popular 70 Series—simply put, the most requested DMM in the world, with nearly 2 million units in service since 1984. And the Fluke 21 and 23—70 Series simplicity in high-visibility yellow.

The Fluke 25 and 27—the most rugged meters ever built, totally sealed against water, dust and other contaminants.

And the precise 8060 Series—with the versatility of a test lab, the accuracy of a bench instrument, and the convenience of a handheld.

**Smart choice.** Compare Fluke DMMs with any other handheld. No one else gives you as much meter for your money. And no other meter costs less to own.

**Your choice.** For the name of your nearest Fluke distributor, call toll-free **1-800-44-FLUKE, ext. 33**. And make a great choice.

John Fluke Mfg. Co., Inc. P.O. Box C9090 M/S 250C Everett, WA 98206 U.S. (206) 356-5400. Canada: (416) 890-7600. Other Countries: (206) 356-5500. © 1989 John Fluke Mfg. Co., Inc. All rights reserved. Ad No. 0491-F70

FROM THE WORLD LEADER  
IN DIGITAL MULTIMETERS

**FLUKE**

Circle (6) on Reply Card

[www.americanradiohistory.com](http://www.americanradiohistory.com)

## EIA announces VICA winners

Six winners of the Electronic Products Servicing Contest received awards donated by members of the consumer electronics industry at the 25th annual Vocational Industrial Clubs of America (VICA) United Skill Olympics, which was part of the VICA National Leadership Conference held June 26-30 in Tulsa, OK. VICA is the national educational organization for students in trade, industrial, technical and health occupations.

The winners in the high-school division are, in first place, Chris Osterloh of Area Vo-Tech School, Monett, MO; in second place, Charles Woods of Bay Minette Area Vocational Center, Bay Minette, AL; and in third place, Todd Pickler of West Stanly High School,

Oakborn, NC. The winners in the post-secondary division are, in first place, David Dore of Twin Lakes Vo-Tech, Harrison, AR; in second place, Patrick Quinn of Boise State University, Boise, ID; and in third place, Lynn Ronnebaum of North Central Kansas Area Vo-Tech School, Beloit, KS.

Prizes included tool cases, test equipment, VCR training tapes, consumer electronics products and subscriptions to *ES&T* magazine. First-place winners also received 2-year scholarships from the Texas Educational Corporation.

The Electronic Industries Association/Consumer Electronics Group (EIA/CEG), a major sponsor of the contest, developed the projects in the contest, acquired the equipment and obtained qualified judges. ■



Winners in the high-school division: first place, Chris Osterloh (center); second place, Charles Woods (left); and third place, Todd Pickler (right).



Winners in the post-secondary division: first place, David Dore (center); second place, Patrick Quinn (left); and third place, Lynn Ronnebaum (right).

The magazine for consumer electronics servicing professionals

# ELECTRONIC

Servicing & Technology

*Electronic Servicing & Technology* is edited for servicing professionals who service consumer electronics equipment. This includes service technicians, field service personnel and avid servicing enthusiasts who repair and maintain audio, video, computer and other consumer electronics equipment.

## EDITORIAL

Nils Conrad Persson, *Editor*  
Tom Cook, *Senior Managing Editor*  
Alisa Carter, *Associate Editor*  
Andrew Naugher, *Editorial Assistant*

## CONSULTING EDITORS

Carl Babcoke, *Consumer Servicing Consultant*  
Homer L. Davidson, *TV Servicing Consultant*  
Christopher H. Fenton, *Circuit Fabrication Consultant*  
William J. Lynott, *Business Consultant*  
Victor Meeldijk, *Components Consultant*  
Kirk G. Vistain, *Audio Consultant*  
Sam Wilson, *Electronics Theory Consultant*

## ART

Barbara Miles, *Graphic Designer*

## BUSINESS

Cameron Bishop, *Group Vice President*  
Eric Jacobson, *Group Publisher*  
Greg Garrison, *Sales Manager*  
Kevin Callahan, *Creative Director*  
Marcia Durrett, *Marketing Director*  
Evelyn Hornaday, *Promotions Manager*  
Darren Sextro, *Promotions Coordinator*  
Dee Unger, *Advertising Business Manager*  
Susan Edwards, *Advertising Coordinator*

## ADVERTISING

Greg Garrison, 913-888-4664

## ADMINISTRATION

R.J. Hancock, *President*  
Chuck Rash, *Corporate Circulation Director*  
Sandra Stewart, *Circulation Director*  
Donna Schagle, *Circulation Manager*  
Customer Service, 913-541-6628



Member, Audit Bureau of Circulation



Member, American Business Press



Member, Electronic Servicing Dealers Association

## CORRESPONDENCE

Editorial and advertising: P.O. Box 12901, Overland Park, KS 66212 (a suburb of Kansas City, MO); 913-888-4664. Circulation: P.O. Box 12960, Overland Park, KS 66212. Home office fax: 913-541-6697. Home office telex: 42-4156 INTERTEC OLPK

**SUBSCRIPTION PRICES:** one year, \$19.49; two years, \$32.98 in the USA and its possessions. Foreign countries: one year, \$23.49; two years, \$36.98. Single copy price: \$3.00; back copies, \$5.00. Adjustment necessitated by subscription termination to single copy rate. Allow 6 to 8 weeks for new subscriptions.

**PHOTOCOPY RIGHTS:** Permission to photocopy for internal or personal use is granted by Intertec Publishing Corp. for libraries and others registered with Copyright Clearance Center (CCC), provided the base fee of \$2 per copy of article is paid directly to CCC, 21 Congress St., Salem, MA 01970. Special requests should be addressed to Eric Jacobson, publisher. ISSN 0278-9922 \$2.00 + 0.00

*Electronic Servicing & Technology* (ISSN 0278-9922) is published monthly for \$19.49 per year by Intertec Publishing Corp., 9221 Quivira Road, Overland Park, KS 66215. Second-class postage paid at Shawnee Mission, KS and additional mailing offices. POSTMASTER: Send address changes to ELECTRONIC SERVICING & TECHNOLOGY, P.O. Box 12960, Overland Park, KS 66212.

©1989 by Intertec Publishing. All rights reserved.







# PHILIPS

# THERE IS NO SMARTER CHOICE THAN PHILIPS ECG.



## ECG PR200A OR PR60: FOR THE RIGHT ANSWER TO YOUR SCOPE PROBE NEEDS.

ECG™ scope probes come packed with features and packed with value. Features on the PR200A include:

- 200 Mhz bandwidth capability
- X1, X10 attenuation and reference switch
- Low input capacitance
- Large thumb switch with positive detents, for easy switching between X1 and X10 and ground reference
- Comes with an IC tip, BNC adaptor, insulating tip and a retractable hook

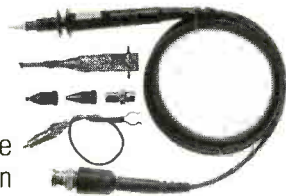

The PR60 features:

- 60 Mhz bandwidth capability
- X1, X10 attenuation and reference switch
- Retractable hook

ECG scope probes: the smart choice.

Circle (28) on Reply Card

## ECG VCR MECHANICAL REPLACEMENT PARTS CATALOG: THE SMART PLACE TO LOOK FOR YOUR REPLACEMENT PARTS.

The ECG VCR mechanical replacement parts catalog has the industry's most comprehensive cross-references to make sure you get the correct part:

- Complete product line includes: 13 pinch rollers, 42 idler wheels and assemblies, 4 idler tires and 48 belt kits
- 55 individual belts also available

ECG VCR replacement parts: the smart choice.

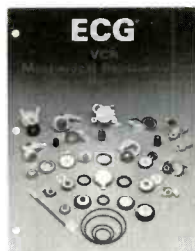

Circle (29) on Reply Card

Contact one of more than 900 distributors or call 1-800-233-8767 for the name of the distributor nearest you. It just might be the smartest call you make all week.

## ECG DM-26 AND DM-27 FULL FUNCTION GENERAL PURPOSE MULTIMETERS.

The ECG DM-26 and DM-27 multimeters are loaded with features and loaded with value. Just check out the array of capabilities:

- Diode test
- Rotary range switch
- Tilt stand
- 0.8% basic DC accuracy
- 3 1/2" digit LCD display, 0.5" high
- 20 MΩ full scale
- 10 MΩ input resistance, DC
- Low power Ohms
- Overload protected
- The DM-27 also includes an audible continuity test



ECG multimeters: the smart choice.

Circle (30) on Reply Card

## ECG TV-1100 CABLE CONVERTER: THE SMART WAY TO MAKE ANY TV CABLE-READY.



The ECG TV-1100 Cable Converter adapts any TV to receive cable channels. And the added features give added value:

- Remote control features on/off, channel selection, and picture fine tuning. Operates from up to 25 feet away
- Converts VHF and cable channels to a switch-selectable output, channel 2 or 3
- Remote control features last channel recall and memory to store up to 10 favorite channels
- Features a sleep timer that automatically turns TV off after pre-determined time (up to 90 minutes)

ECG cable converter: the smart choice.

Circle (31) on Reply Card

## Philips ECG Company

A Division of North American Philips Corporation

© 1989, Philips ECG Company

# Test your electronics knowledge

By Sam Wilson, CET

Here is a review of the basic rules for Boolean algebra. The rules are represented by logic circuits. In each case, write the rule in the space provided using the letters given in the drawing.

One good method of arriving at the

Wilson is the electronics theory consultant for ES&T.

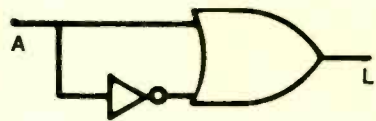

1.



2.

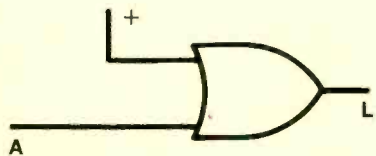

3.

solutions is the use of truth tables. In the next two months, we'll continue our discussion of this subject in "What Do You Know About Electronics." In November, we'll discuss logic circuits and Boolean algebra. In December, we'll discuss the solutions to the questions in this quiz.

Answers are on page 37.

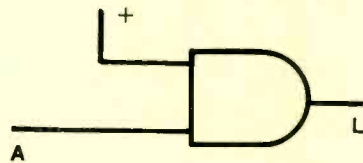

4.

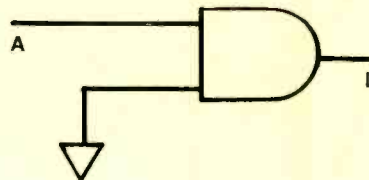

5.

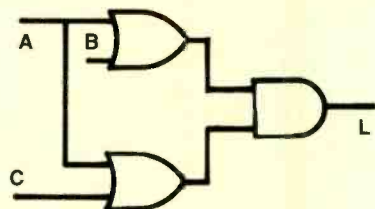

6.

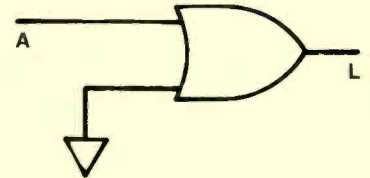

7.

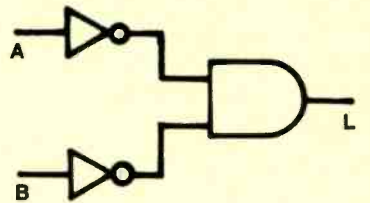

8.

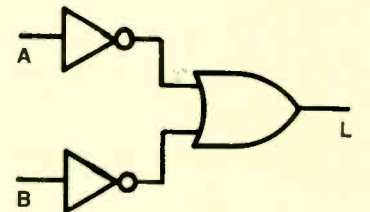

9.

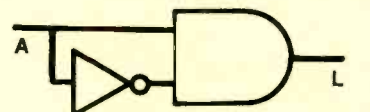

10.

# EXPAND YOUR CAREER HORIZONS...



*The CIE Microprocessor Trainer helps you to learn how circuits with microprocessors function in computers.*

## START WITH CIE.

Microprocessor Technology. Satellite Communications. Robotics. Wherever you want to go in electronics... start first with CIE.

Why CIE? Because we're the leader in teaching electronics through independent study. Consider this. We teach over 25,000 students from all over the United States and in over 70 foreign countries. And we've been doing it for over 50 years, helping thousands of men and women get started in electronics careers.

We offer flexible training to meet your needs. You can start at the beginner level or, if you already know something about electronics, you may want to start at a higher level. But wherever you start, you can go as far as you like. You can even earn your Associate in Applied Science Degree in Electronics.

Let us get you started today. Just call toll-free **1-800-321-2155** (in Ohio, 1-800-362-2105) or mail in

Circle (8) on Reply Card

the handy reply coupon or card below to:  
Cleveland Institute of Electronics,  
1776 East 17th Street, Cleveland, Ohio 44114.

### **CIE** World Headquarters

**Cleveland Institute of Electronics, Inc.**  
1776 East 17th Street • Cleveland, Ohio 44114

Please send your independent study catalog.  
For your convenience, CIE will try to have a representative contact you — there is no obligation.

Print Name \_\_\_\_\_

Address \_\_\_\_\_ Apt. \_\_\_\_\_

City \_\_\_\_\_ State \_\_\_\_\_ Zip \_\_\_\_\_

Age \_\_\_\_\_ Area Code/Phone No. \_\_\_\_\_

Check box for G.I. Bill bulletin on Educational Benefits

Veteran  Active Duty **MAIL TODAY!**

Just call toll-free **1-800-321-2155** (in Ohio, 1-800-362-2105)

AES-43

# Basic compact-disc player servicing techniques

By Homer L. Davidson

If you've been in a record store lately, you've probably noticed that "record" stores are quickly becoming compact disc (CD) stores. In fact, with a modest average price of about \$250, it's no wonder 6.5 million CD players will be sold this year. Of course, the upsurge of CD sales can be a boon to the electronics servicer who wants to branch out in new directions, and because CD players are only owned by about 15% of American households, the situation can only get better.

If you're interested in CD servicing, there are a few CD basics and principles with which you should become fa-

miliar. For openers, just knowing how to operate the CD player may save a few unnecessary repairs and wasted time. Basic CD player circuit operation is fairly straightforward, but a knowledge of how to handle IC chips and surface-mount components may save a few damaged parts and a lot of frustration on the part of the servicer.

## Basic CD players

CD players come in several forms: home, auto, portable and combination players. The home CD player operates from the power line and is connected as part of the stereo system, usually along with, or in place of, the turntable or changer. These home CD players may

be front- or top-loading machines. An automatic disc changer can play several discs in succession.

A car stereo player may be part of the audio system that comes with a new car, or it can be added to an existing stereo audio system. Most of these players are front loading, but an automatic disc changer may be placed in the trunk area. The basic auto CD circuits are the same as the home units, except they are powered by the auto battery and may include a dc-to-dc converter in the power supply. The auto CD player may be contained in two different units, one a hideaway unit.

Most portable CD players are battery-powered and used with earphones, like

---

Davidson is the TV servicing consultant for ES&T.

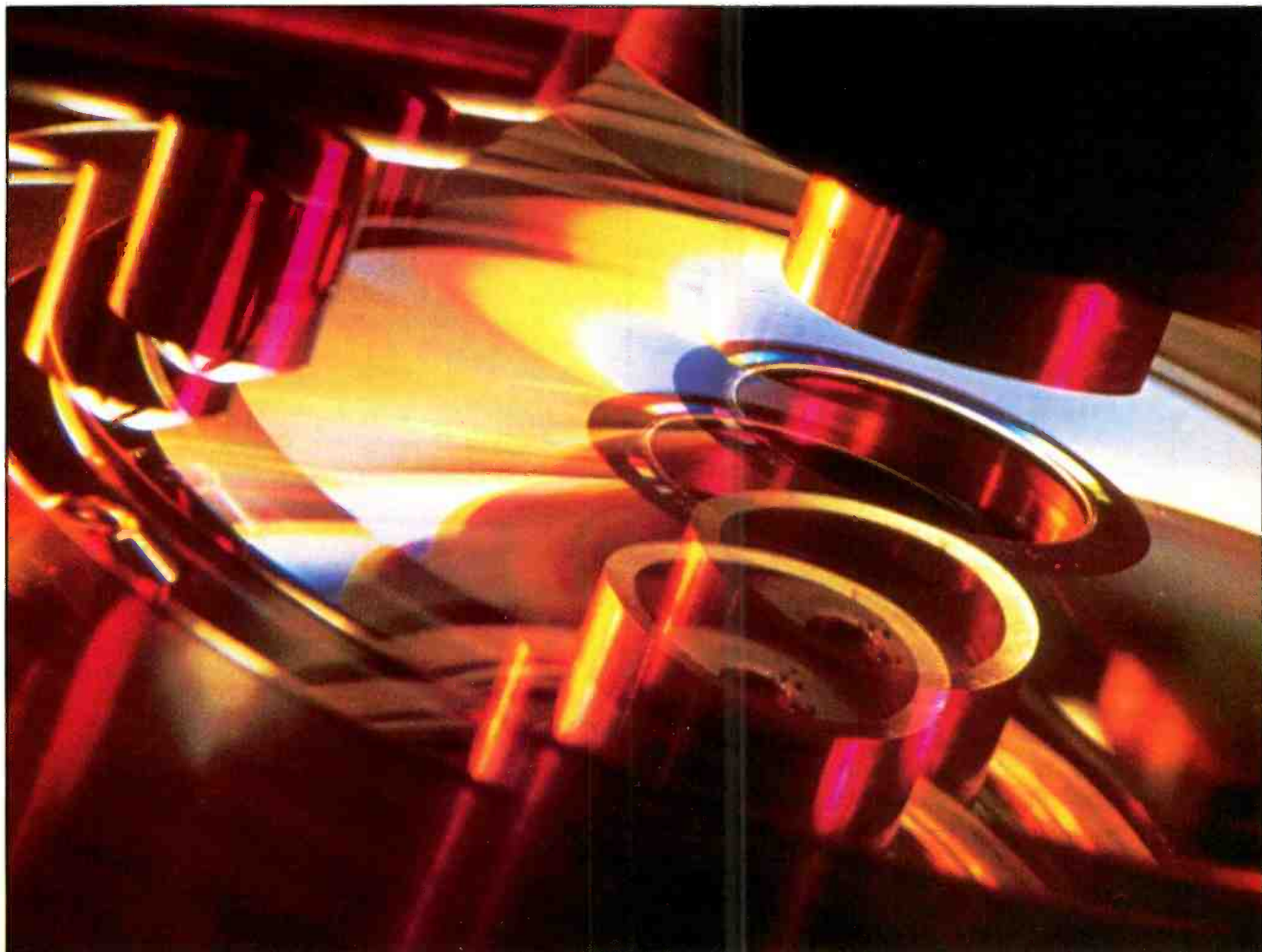

the portable stereo cassette player. Many people also use portable units just as they would one that was designed for use in the home, plugging them directly into a stereo amp and operating them from the power line.

### Safety precautions

There are several safety factors you should observe before and during service procedures:

- Always keep a CD disc on the turntable or cover the laser while servicing the disc player.
- Do not look directly at the laser beam when servicing the CD player. It may damage your eyes. Remember, you cannot see this beam with the naked eye.
- Wear a grounding wrist strap to prevent electrostatic discharge (ESD) damage to those delicate chips and processors. Keep a conductive mat under test equipment and the CD player while servicing.

- Use extreme care when handling the laser beam assembly. Follow the manufacturer's procedures.

- Replace all parts with exact manufacturer's replacement units, especially those marked with a safety symbol. Be careful when removing and installing ICs and processor components.

- After you complete a repair, don't forget to remove test clips and shorting devices that you might have placed across interlocks in performing diagnostic tests.

- Always perform leakage current checks after repairs are completed.

The resistance insulation, leakage current and hot current tests should be made after all repairs are done and before you clean up the CD cabinet. For resistance checks, turn the power switch on with the unit not plugged into the ac power. Measure the resistance between both ac plug terminals and exposed metal parts of the CD player. (See Figure

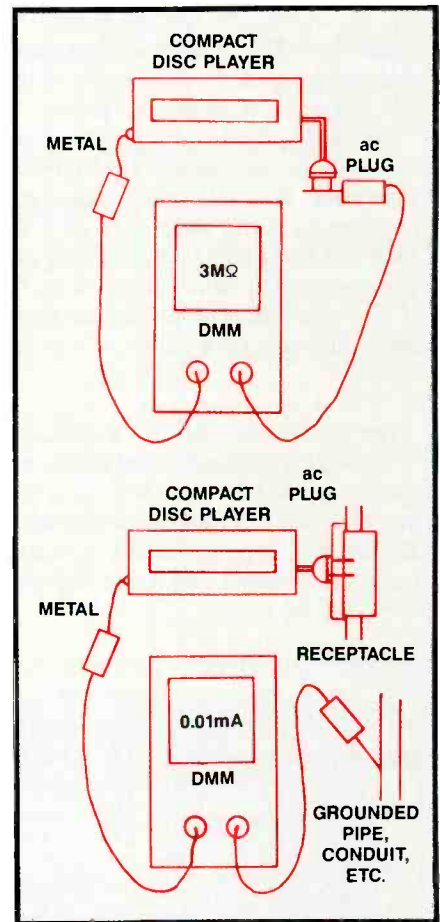

Figure 1. To prevent shock hazard, either a resistance or hot current check should be made.

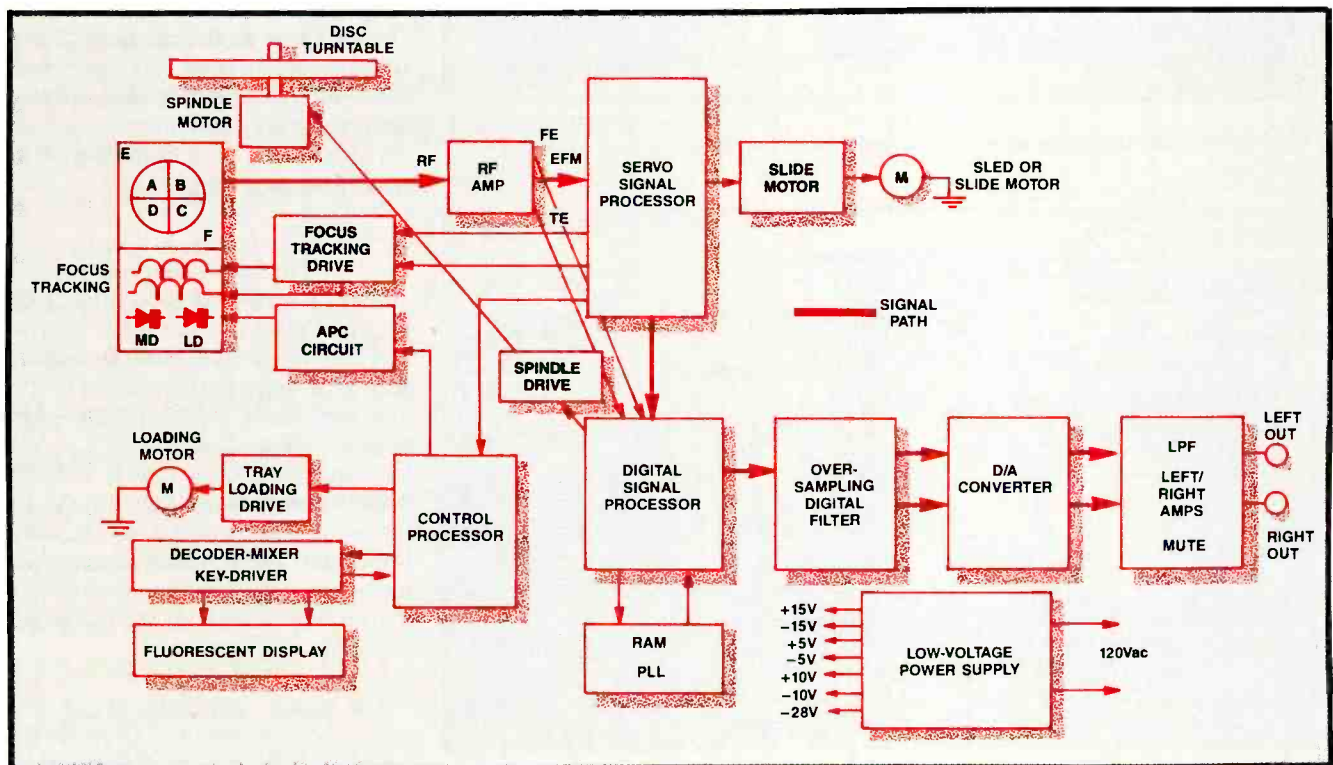

Figure 2. Use a block diagram, such as this diagram of the Cannon CD player, to locate the possible defective section.

1.) The resistance reading should be higher than  $1M\Omega$ . If the resistance is less than  $1M\Omega$ , check the reassembly of the CD player for possible shorts.

For the hot current test, plug the player into the power receptacle and turn the switch on. Take a current leakage test between the player and a good ground, such as a water pipe or wiring conduit. The current should not exceed 0.5mA. If the measurement is outside these limits, there is a possibility of a shock hazard.

### Test equipment for CD servicing

The digital multimeter and dual-trace oscilloscope are the two most important pieces of test equipment for servicing CD circuits. Most of these test instruments are already found on the electron-

ics technician's service bench. Here is a list of the basic test equipment and tools:

- digital multimeter or VOM
- dual-trace oscilloscope
- optical power meter
- AF oscillator
- capacitance meter
- signal generator
- frequency counter
- test discs
- special tools, manufacturer's special test jigs, wrist strap.

The oscilloscope may be used to troubleshoot the various waveforms found throughout the signal, servo and motor circuits. In fact, the scope waveform can be used to signal-trace right up to the motor terminals. The oscilloscope is used to make critical adjust-

ments of the RF, focus gain, tracking gain, tracking balance and PLL circuits.

Many of the special test instruments and jigs are purchased from the manufacturer. The optical power meter is used to check the condition of the laser beam diode. Test discs may be used for troubleshooting and critical adjustments. Special test-jigs and harnesses may be required for certain tests that are recommended or specified by the manufacturer.

### CD player operation

Knowing how the CD player operates may save a lot of time and trouble. Read the owner's or manufacturer's service manual. If that's not handy, remember they all operate in about the same manner. Improper operation of the front controls may cause you to take a little longer to service the unit.

The Open/Close switch controls the loading tray. This button opens the loading tray so the disc can be loaded. Once you have placed the disc in the tray (label side up), press the button again to close the tray and begin play. The other front-panel operating keys are fairly self-explanatory: the Play key begins playback; the Pause key temporarily interrupts playback; the Stop key stops all operations; the Track Search key searches for a desired track; the Reverse key returns the pickup to the beginning of the track. When the player is in the Play or Pause mode, the Index Search keys are used to search for index numbers within individual tracks. Although there are many other time and memory keys found on other CD players, the basic CD functions may be applied to any CD player.

### The block diagram

When a malfunction occurs in a CD player, a glance at the block diagram will help you quickly locate the stage or section in which the breakdown occurs. You may check the signal path from stage to stage. (See Figure 2.) After locating the section or stage in which the defect has most likely occurred, you can locate that section on the large schematic diagram. The servicing literature may include several different schematics of the various sections in the CD player.

### Basic circuits

The signal path starts at the laser pickup head where the pits on the disc are converted into a digital electrical signal. This signal is amplified by the RF

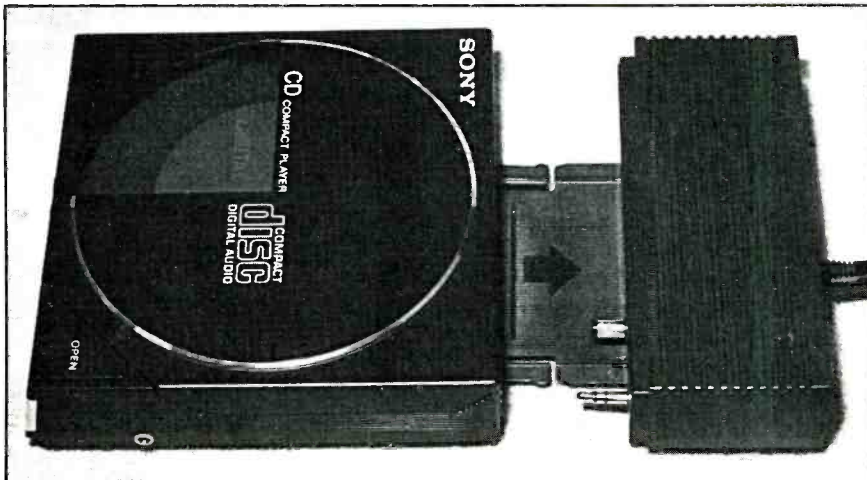

The portable CD player may be plugged directly into a stereo amp and operated from the power line.

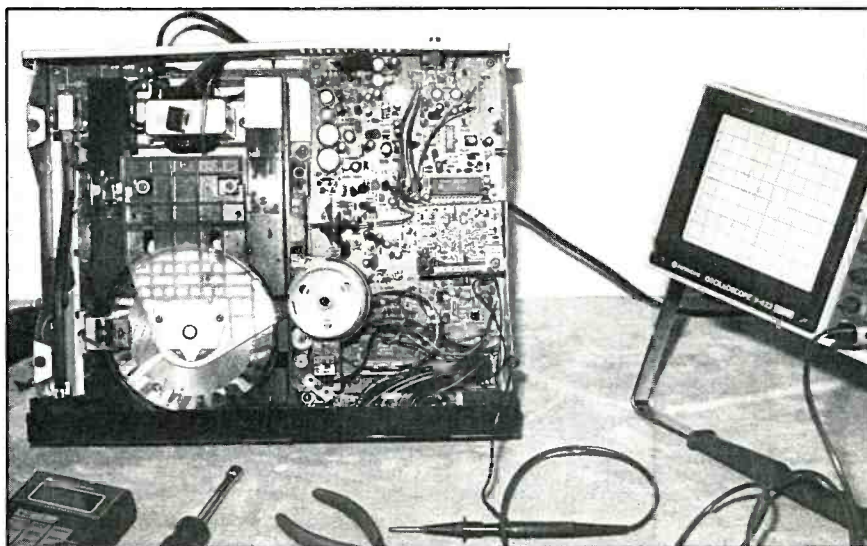

The two most important test instruments required to service the CD player are the digital multimeter (DMM) and the oscilloscope.

# PC Troubleshooting and Repair Products and Services

from

## Windsor Technologies



### PC-Technician

A complete family of diskette-based diagnostic systems for IBM PCs and compatible computers.

### WindsorPOST

A family of unique ROM-based diagnostic products for service shop and repair depot.

### Education and Documentation Services

Comprehensive standard or custom classroom-based computer repair and troubleshooting training, plus service documentation support.

### Windsor Technologies, Inc.

130 Alto Street,  
San Rafael, California 94901  
(415) 456-2200  
FAX: (415) 456-2244

Circle (9) on Reply Card

PC-Technician and WindsorPOST are trademarks of Windsor Technologies, Inc., and IBM PC, PC XT, PC AT are trademarks of International Business Machines Corporation.

Mail to: **Windsor Technologies, Inc.**

130 Alto Street, San Rafael, CA 94901  
(415) 456-2200; FAX: (415) 456-2244

Please send me the following:

FREE PC-Technician Evaluation Diskette:

IBM PC, PC XT, PC AT

IBM PS/2 Group

WindsorPOST information

Windsor Education & Documentation Services information

NAME \_\_\_\_\_ TITLE \_\_\_\_\_

COMPANY \_\_\_\_\_ TELEPHONE \_\_\_\_\_

ADDRESS \_\_\_\_\_

CITY \_\_\_\_\_ STATE \_\_\_\_\_ ZIP \_\_\_\_\_

SERVICE CO.  OEM  MANUFACTURER  DEALER  VAR/VAD

IN-HOUSE SERVICE  USER  OTHER \_\_\_\_\_

ES&T 1089

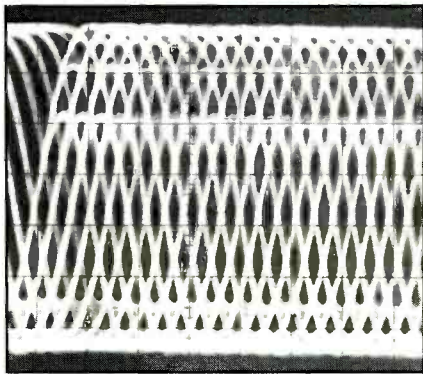

**Figure 3.** Many circuits will not function without this RF signal eye waveform found at the RF amplifier.

signal amplifiers. (See Figure 3.) This digitally encoded signal (known as EFM for 8-to-14 modulation because of the method of encoding) passes through the servo controller, the LSI signal processor, and the left and right sample/hold circuits. When the signal reaches the digital-to-analog (D/A) converter, it is changed from a digital signal to a stereo audio signal.

The stereo audio signal passes through a low-pass filter (LPF) network and the amplifiers, then to each left and right channel output jack. Some CD players have built-in stereo headphone amplifiers for quiet listening.

The focus amp, focus error amp and auto focus ensure that the laser beam is focused on the right pits. Keeping the laser beam on track is controlled by the tracking amp and tracking error amp. Most of the CD player operations are controlled by the operations-control LSI processor. The loading and transverse or sled motor operations are controlled by the same IC chip.

The servo control IC provides signal and power to the focus and tracking coil drives, the slide or sled motor drive, the spindle servo, the tray motor drive, and the track jump and search circuits. Often, one large LSI or two ICs may control most CD operations. The spindle motor, which rotates the CD, may be operated by the servo IC.

The low-voltage power supply provides different voltages to the various circuits. You may find separate positive and negative 5V, 10V, 12V and 15V sources in the power circuits. A separate -28V source powers the fluorescent tube indicator. Remember, one defective voltage source may disable more than one circuit in the CD player.

### The compact disc

The CD may have up to 74 minutes

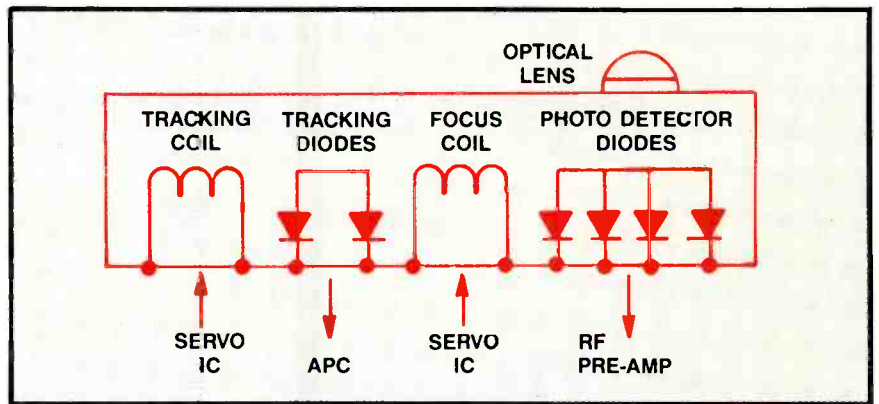

**Figure 4.** The laser pickup assembly may contain the photodetector diodes, two tracking photodetectors, focus and tracking coils, a monitor diode and APC circuits.

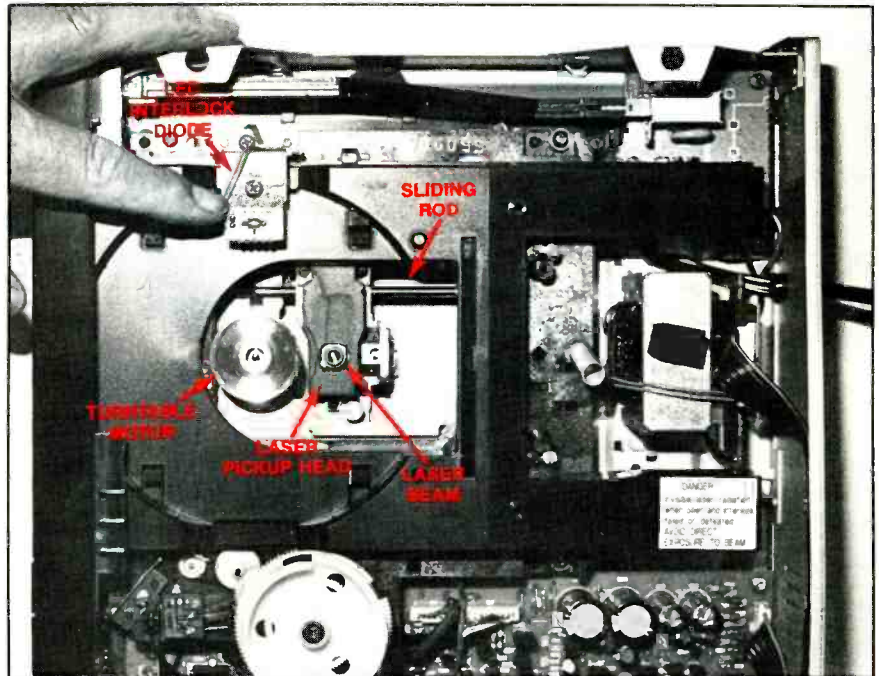

**Figure 5.** The laser pickup assembly is operated by the sled motor. The disc turntable rotates the spindle motor.

of music on a disc less than five inches in diameter. The disc contains microscopic indentations called pits, with non-indented areas (spaces) between them. These pits and the spaces between pits are the digitally encoded representation of the analog audio information. The high-density information on these tracks is read by a laser pickup with no physical contact between the pickup and the disc surface. This music information is recorded on the bottom of the disc; the opposite side contains the disc identification information.

Unlike analog discs, compact discs are recorded and read from the center of the disc to the outside edge. The disc starts out at a speed of 500rpm and slows down to 200rpm as the laser pick-

up travels from the center to the outside edge of the disc. This reduction in rotational speed occurs because it is necessary that the linear velocity of the disc pits past the laser pickup remain constant. The spindle motor rotates the disc turntable. A slide, transverse or sled motor moves the laser beam assembly from the center to the outside edge as the disc rotates. You may find that each manufacturer has a different name for the various CD motors.

### The laser beam

The laser pickup assembly consists of photodetector diodes that sense the EFM signal from the disc. The output of this assembly connects to the RF amplifier. The RF signal is weak and must be amplified by the RF pre-amplifier



Now electronics technicians can get into VCR Servicing quickly and easily

# Learn professional VCR servicing at home or in your shop with exclusive videotaped demonstrations

Today, there are more than 10 million VCRs in use, with people standing in line to have them serviced. You can bring this profitable business into your shop with NRI professional training in VCR servicing. This top-level training supports the industry's claim that the best technicians today are those who service VCRs.

## Integrated Three-Way Self-Teaching Program

In one integrated program, NRI gives you a study guide, 9 instructional units, 2 hours of video training tapes accompanied by a 32-page workbook that pulls it all together. At home or in your shop, you'll cover all the basic concepts of video recording, mechanical and electronic systems analyses, and the latest troubleshooting techniques. Your workbook and instructional units also contain an abundance of diagrams, data, and supplementary material that makes them valuable additions to your servicing library.

## The "How-To" Videotape

Your NRI Action Videocassette uses every modern communications technique to make learning fast and easy. You'll enjoy expert lectures and see animation and video graphics that make every point crystal-clear. You'll follow the camera eye into the heart of the VCR as step-by-step servicing techniques are shown. Both electronic and mechanical troubleshooting are covered . . . including everything from complete replacement and adjustment of the recording heads to diagnosing micro-processor control faults.

## Plus Training On All The New Video Systems

Although your course concentrates on VCRs covering Beta, VHS, and 3/4" U-Matic commercial VCRs, NRI also brings you up to speed in other key areas. You'll get training in capacitance and optical video disc players, projection TV, and video cameras. All are included to make you the complete video technician. There's even an optional final examination for NRI's VCR Professional Certificate.



Covers Beta and VHS systems with actual instruction on videotape.

## The Best Professional Training

This exclusive self-study course has been developed by the professionals at NRI. NRI has trained more television technicians than any other electronics school! In fact, NRI has consistently led the way in developing troubleshooting techniques for servicing virtually every piece of home entertainment equipment as it appears in the marketplace.

## Satisfaction Guaranteed . . . 15-Day No-Risk Examination

Send today for the new NRI Self-Study Course in VCR Servicing for

Professionals. Examine it for 15 full days, look over the lessons, sample the videotape. If you're not fully satisfied that this is the kind of training you and your people need to get into the profitable VCR servicing business, return it for a prompt and full refund, including postage. Act now, and start adding new business to your business.

## Special Introductory Offer

This complete VCR training course with two hour videotape is being offered for a limited time only, on orders received from this ad, at our low introductory price of \$179.95. Save \$20 by acting now!

NRI Training For Professionals  
McGraw-Hill Continuing Education Center  
4401 Connecticut Avenue, NW, Washington, DC 20008

**YES!** Get me started in profitable VCR servicing. Rush me my NRI self-study course in VCR Servicing for Professionals. I understand I may return it for a full refund within 15 days if not completely satisfied.

**NRI SCHOOLS**  
McGraw-Hill Continuing Education Center  
4401 Connecticut Avenue, NW  
Washington, DC 20008

PLEASE SPECIFY TAPE FORMAT DESIRED  VHS  BETA

Name (please print) \_\_\_\_\_

Company \_\_\_\_\_

Street \_\_\_\_\_

City/State/Zip \_\_\_\_\_

Enclosed is my  check  money order for \$179.95 (D.C. residents add 6% tax) Make check payable to NRI

Charge to  VISA  MasterCard \_\_\_\_\_  
Interbank Number \_\_\_\_\_

Card Number \_\_\_\_\_ Expiration Date \_\_\_\_\_

Signature \_\_\_\_\_

(required for credit card sales)

Accredited Member National Home Study Council

2630-109

AD#2

circuit. Besides supplying the EFM signal, the photodetector diodes provide a tracking error signal to keep the beam on track. (See Figure 4.)

The focus and tracking coils are located close to the optical lens. The focus coil keeps the beam focus on the correct disc surface while the tracking coils provide precise tracking as the disc rotates. (See Figure 5.)

You can check the continuity of the focus and tracking coils with an ohmmeter. The focus coil may measure between  $20\Omega$  and  $30\Omega$ ; the tracking coil may measure  $4\Omega$  to  $10\Omega$ .

### Where to begin

Before digging into a malfunctioning CD player, make sure the transport screws are loosened or removed from underneath the player. These screws hold the laser assembly in place while the player is in transit. If these screws are not removed, the player may shut off and not operate. A lot of CD players are brought in for repairs when the only problem is that the transit screws are still in place.

Check for the presence of interlock

switches or interlock protection laser circuits before servicing the unit. In many units, if the disc is not in place, the LED shuts down the laser beam. In top-loading disc players, the cover may shut off the player if it is not closed for operation. These interlocks may be disabled by shunting clip leads across the interlock switch terminals. CAUTION: If you must disable the laser interlock, DO NOT look at the laser beam assembly while servicing the player with power on.

Locate the suspected defective stages on the block diagram. Check the low voltage supplied to the defective circuit. You may find both a negative and positive voltage in each circuit. Improper voltage within the low-voltage power supply may cause more than one circuit to malfunction.

Scope the various circuits for missing waveforms. The focus and tracking waveforms can be traced right to the coil windings. The servo motor signals may be scoped from the servo control processor to the drive motor IC or transistor, then right to the motor terminals. Voltage measurements at the motor and

continuity coil winding may identify a defective motor.

### How to handle chips

There are many ICs in the CD player. In fact, there are very few transistors scattered throughout the chassis. These components should be handled with care. Removing the part is no problem because it is never used again. Extreme care should be exercised, however, not to damage the printed circuit wiring under and around the IC. Some ICs have up to 80 terminal connections.

One method of removing multilead ICs is to remove the solder around the terminals with solder wick or a desoldering tool. Suck up the excess solder from all terminals before attempting to lift the chip from the board. Lay the wick mesh over the row of terminals. Heat the wick and pick up excess solder. Be careful not to apply too much heat in one area or the wiring may lift from the phenolic board. Remember, some of these boards are double-sided, with wiring and parts on both sides of the board.

ICs and LSI processors are sensitive to static electricity. Some come packaged inside foil or static bags. Do not remove these components from their packing until you are ready to replace the component. Keep the static wrist strap grounded to the CD player metal chassis. Keep all tools away from sensitive components until they are mounted. Solder terminals with a 20W to 35W soldering iron, preferably one that has a grounded tip so it will not introduce ESD damage.

### Surface-mount components

Surface-mount parts are found throughout the CD player. These components are mounted on the same side of the board as the etched wiring. The IC terminal connections come out of the side of the package and lie flat on the wiring. With surface-mount capacitors and resistors, each solid end is soldered directly to the wiring.

In order to remove a surface-mount device, start by reducing the amount of solder on each pin of the IC processor with a solder sucker or solder wick. Do not apply heat to one area for a long time. Once the excess solder has been removed from all of the pins, use a sharp, pencil-type iron to melt the solder around one pin at a time. While the solder is melted, lift up the pin with a

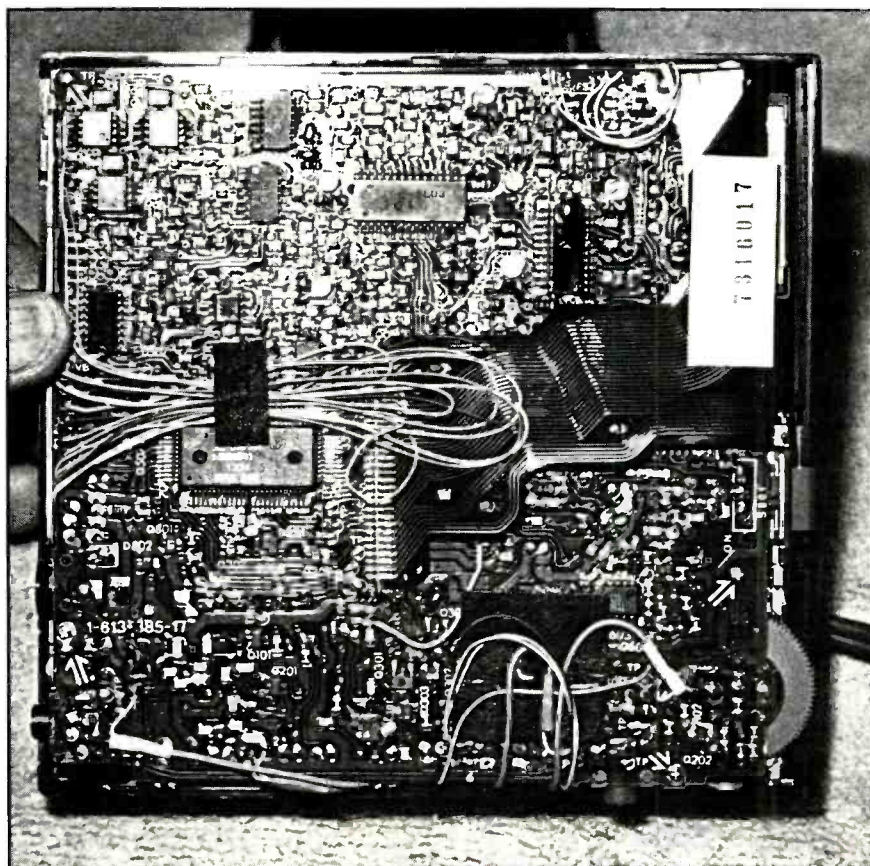

Surface-mount components may be found throughout the CD player. These parts may be found on each side of double-sided wiring boards.

pair of long-nose pliers or some other fine-tipped device. Do not pry up the component when the solder is cold. Part of the printed circuit wiring may come up with the component.

Clean up around the area where the defective part was mounted. A clean soldering iron tip may be all you need. Make sure all excess solder is removed from each terminal end of the printed circuit wiring before replacement. Remove the component from the package and place correctly over the etched wiring. Observe the identification dot or terminal one of the processor. Make a good soldering joint, but do it quickly to avoid damage to the printed circuit wiring and the surface-mount device.

### Op-amps

There are many IC operational amplifiers (op-amps) found in a CD player. This component is a high-gain, directly coupled differential amplifier with two separate inputs. When a signal is applied to the non-inverting (positive) terminal, the phase or polarity of the output is the same as the input. The output signal is shifted 180° when the

**When servicing CD players, always replace the defective component with the original part number. The original part will line up perfectly with the printed circuit wiring, and you can save yourself from wasting a lot of time and money trying to make non-standard parts fit.**

signal is applied to the inverting (negative) terminals.

These op-amps are found in tracking error, servo loop, focus error, audio and motor circuits as well as many other circuits in the CD player. Op-amps may operate in inverter, non-inverter, comparator, add, feedback and amplifier circuits. You can identify op-amps by their positive and negative inputs and the separate positive and negative supply voltages applied to them.

### Parts replacement

When servicing CD players, always replace the defective component with the original part number. The original part will line up perfectly with the printed circuit wiring, and you can save yourself from wasting a lot of time and money trying to make non-standard parts fit. As with other consumer electronic products, the manufacturer may produce one unit under several different brand names. Of course, the components in these units are identical and may be interchanged for replacement. Replace all large components, such as laser pickup heads, mechanical gears, plastic pieces, LSI processors, motors and special moving components, with the original part number.

*Editor's note: This article was adapted by the author courtesy of TAB Books. For more detailed information on servicing CDs, consult "Troubleshooting and Repairing Compact Disc Players," by Homer Davidson, #3107 (paperback, \$17.95; hardbound, \$26.95), published by TAB Books, Blue Ridge Summit, PA 17294-0850; 800-822-8138.* ■

# Talk of

As Seen in the June '89 Issue of ES&T — Report from the test lab.

THE MAGAZINE FOR CONSUMER ELECTRONICS SERVICING

# ELECTRO

Servicing & Technology

This is an analog scope? • HDTV proposal  
Servicing the RCA CTC107 color

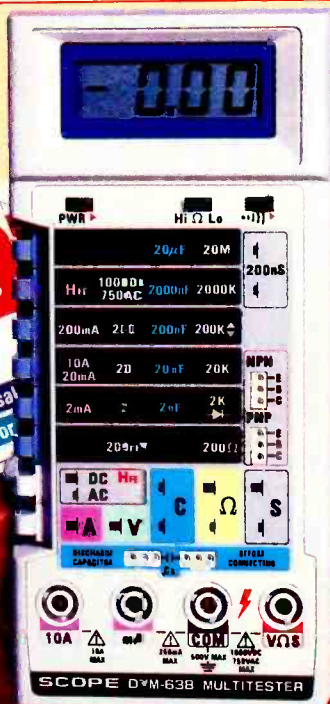

# the town!

"PERFORMED WELL IN ALL TESTS . . ."

"A WELCOME ADDITION TO ANY SHOP OR LAB . . ."

"IMPORTANT EXTRA FEATURES ABOVE THE AVERAGE DVM . . ."

"REASONABLE PRICE IS AN EXTRA BONUS . . ."

### SCOPE DIGITAL MULTIMETER

- 11 function, 38 ranges including Logic Level Detector, Audible Visual Continuity, Capacitance and Conductance measurements
- Polarity indicator

Model DVM-638 **\$79<sup>95</sup>**  
Special! Plus \$5.50 Shipping & Handling

# Fordham

Toll Free **800-645-9518**  
260 Motor Parkway, Hauppauge, New York 11788 In NY State 800-832-1446

Send for FREE catalog of hundreds of items.  
Money orders, checks accepted.  
C.O.D.'s require 25% deposit.



Circle (10) on Reply Card



**Soldering tool catalog**

*Ungar* has published a catalog describing its updated line of soldering and desoldering equipment for the electronics industry. The 28-page illustrated catalog describes the company's surface-mount rework systems, desoldering service centers, soldering systems, soldering/desoldering irons, tips and accessories, heat guns and rechargeable cordless tools. Included in the catalog are construction features, specifications, MIL-SPEC compliance, ordering information and tip-selection guidelines.

Circle (125) on Reply Card

**Semiconductor replacement guide**

*Philips ECG* has published a 24-page supplement to its "ECG Semiconductor Master Replacement Guide." The supplement contains electrical and mechanical specifications for 77 new ECG types, including transistors, industrial rectifiers, silicon-controlled rectifiers, ICs and IC accessories. It also features a cross-reference section listing more than 7,600 additional industry part numbers.

Circle (126) on Reply Card

**Test equipment catalog**

*A.W. Sperry Instruments* is offering the MC-600 Issue C catalog, a 35-page catalog that lists the company's complete line of products. All specifications and accessories are included. Featured in the catalog are three additions to the Digi-snap Digital Snap-Around Volt-Ohm-Ammeters, the DSA-2007, the DSA-2002P with peak hold, and the DSA-2009 true rms ac/dc meter. Also described is the TACH-1 Photo/Contact digital tachometer, the SMW-1 Microcheck non-contact microwave leakage detector, the DM-4000A 3 1/2-digit DMM, the SMA-1A ac milliammeter, and the SVM-1A ac voltage monitor.

Circle (127) on Reply Card

**Spanish pamphlets**

The third and fourth pamphlets in a 5-part consumer education series written in Spanish have been released by the Consumer Affairs Department of the Electronic Industries Association's Consumer Electronics Group (EIA/CEG).

"Consumers Should Know: How to

Buy, Use and Care for VCRs, Camcorders and Tape" and "Consumers Should Know: About Service Contracts; About Repair Service" have been produced to provide Spanish-speaking consumers with information on the purchase, care and service of home electronics. For a list of available pamphlets or for a copy

of these pamphlets, send a self-addressed, stamped envelope with a 25-cent stamp for each pamphlet. On the envelope, request "VCR — Spanish," "Service Contracts — Spanish" or "Pamphlet listing." The address is P.O. Box 19100, Washington, DC 20036.

Circle (128) on Reply Card

# Instrumentation. Cover to Cover.

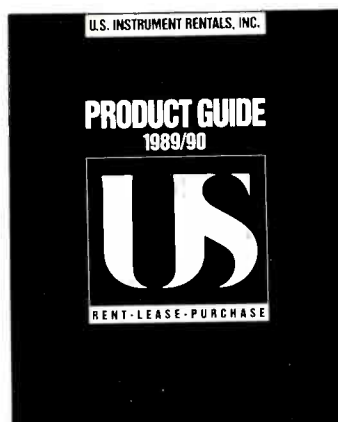

**800-824-2873**  
RENT-LEASE-PURCHASE

With the new 1989/90 Product Guide from U.S. Instrument Rentals that's exactly what you get. This hardbound guide is packed with over 5000 products from more than 170 major manufacturers. Browse through our comprehensive product sections—analyzers, counters, oscilloscopes, microprocessor development systems, computer products, power sources, generators, telecommunications products—and more!

The detailed product descriptions, product photos, and unbiased, thorough product comparison charts help speed your product decisions, and provide you with a valuable reference tool you'll come to rely on. We're sure you'll find this to be the most complete, authoritative guide to instrumentation available.

Call or write for your free copy, and let our 1989/90 Product Guide begin working for you.



Product Specification Charts



Detailed Product Descriptions with Photos

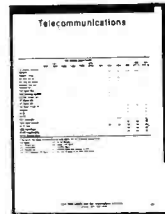

Unbiased Manufacturer's Comparison Charts

**United States Instrument Rentals, Inc.**



A U.S. Leasing Company  
2988 Campus Drive  
San Mateo, CA 94403  
800-824-2873

Circle (11) on Reply Card

# Servicing Zenith microcomputers

## Part IV: Semiconductor memory devices

By John A. Ross

One of the essential components in every computer is a place to store instructions and data. The standard term for this portion of a computer is *memory*. Memory devices store numerical data (unprocessed numbers, calculations and flag bits), alphabetic information (words or messages) and sequential instruc-

tions, called programs, for computer operation. Some variables affect the type of memory operation that the microcomputer requires. Different applications cause differing degrees of information usage and length. For example, a processor used for simple motor control will not require the amount of memory that a microcomputer will need.

The type of microprocessor or memory IC obviously also affects the type

and length of the operations. In memory devices, a variable called *access time*, which can vary from 100ns to 250ns, changes the type of operation. Each memory device, therefore, must have an access time that matches the access time of the system processor. For the technician, this rule becomes important when you add memory to the user's system. Aside from the access-time rule, the technician should also remember that

Ross is a technical writer and a microcomputer consultant for Fort Hays State University, Hays, KS.

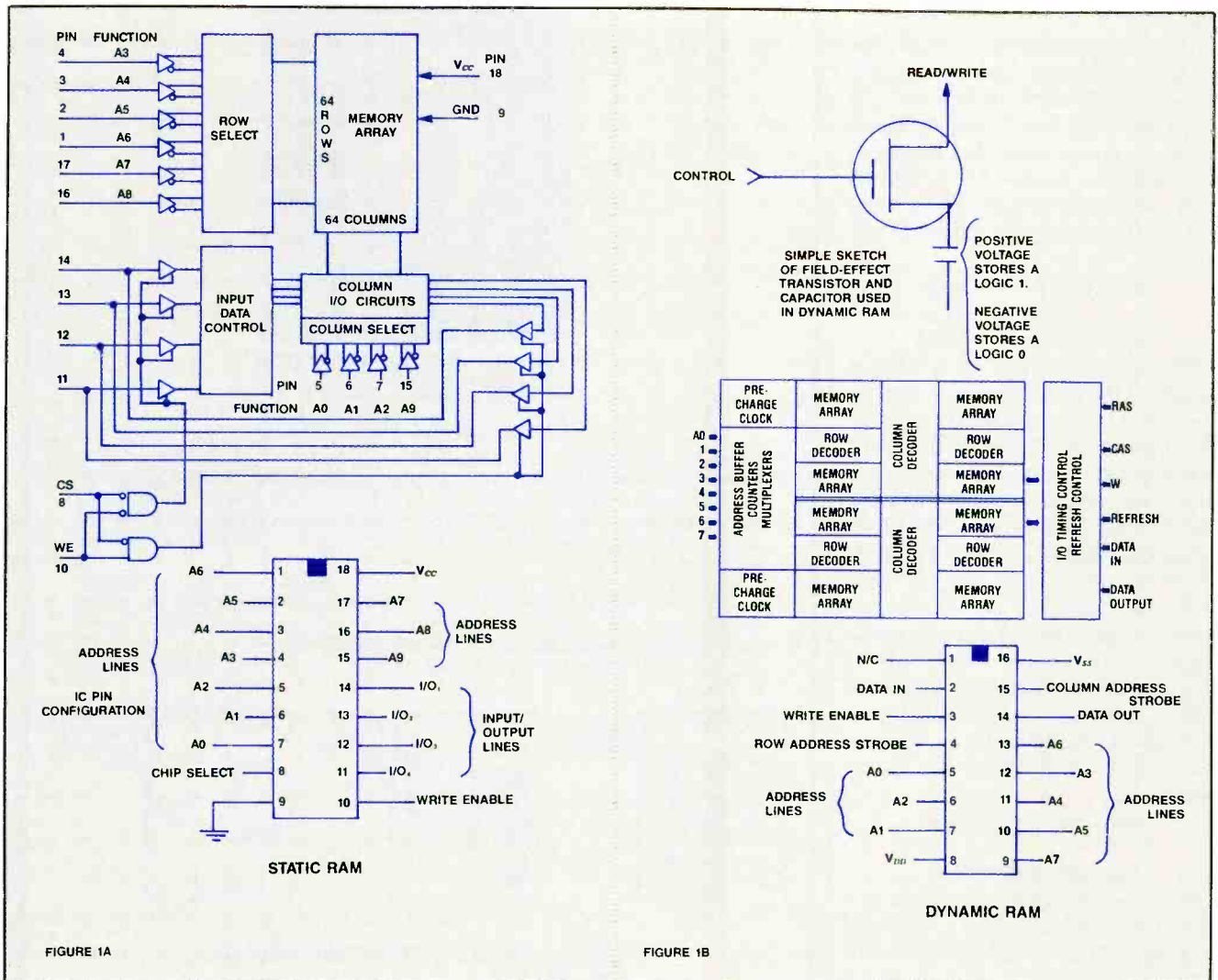

Figure 1. The static RAM, shown in Figure 1A, uses a flip-flop for a storage mechanism. Modern computers use the dynamic RAM, or DRAM (Figure 1B). One bit of a dynamic RAM consists of a single transistor and a capacitor constructed on the IC die, which allows it to store more memory and use less power than the static RAM.

memory ICs are available in 16K, 64K and 256K increments.

When performing a system memory upgrade for a customer, the technician will also discover that he must configure several switches, contained on either the central processing unit (CPU) card or the memory card, to match the size of the system memory. Most memory cards contain five banks of nine memory IC sockets with banks zero and one containing the system base memory. Of the nine identical ICs, eight function as RAM devices; the other acts as a parity device. Most users will need added memory for such applications as large spreadsheet programs. Filling the remaining banks will let the user access the added memory. Forgetting to set the proper switches or jumpers will not let the microprocessor "see" that it can access the added memory.

### The anatomy of memory

In Parts I through III of this series, we compared by analogy the backplane of the microcomputer to the blood-

stream of a human and the actions of the CPU to the actions of a human brain. As with a human brain, the computer also requires a memory. The microprocessor breaks down into the three distinct sections — control, address and memory — and forms a minuscule computer. In the previous descriptions of the circuitry involved in microcomputer operation, we have looked at several singular uses of both random-access memory (RAM) and read-only memory (ROM) devices.

Technically, we could classify both types of devices as random-access devices. However, we will always refer to devices that feature permanent data storage as ROMs. We will call devices that feature temporary data storage RAMs. RAM devices temporarily hold data, such as word processing software, for the microprocessor. During a typical work day, the microcomputer user may load many different types of software into the RAM with no problems.

RAM is called volatile memory: Any loss of electrical power to the RAM will

result in a loss of data. Read-only devices, such as the monitor ROMs on the CPU card, permanently contain data, such as the boot firmware, required for the preliminary operations of the microcomputer.

One type, called *static RAM*, shown in Figure 1A, features simplified operating characteristics. Modern computers, however, use another type of RAM called the *dynamic RAM* or DRAM (Figure 1B). You might ask, "If static RAMs require little circuitry and have such an easily understood design, why not use those devices for larger scale applications?" Simplicity does have a few faults, however.

First, the static RAM, because of its design, cannot offer the memory capacity needed in the microcomputers of today. Seeing that the static RAM uses flip-flops to store each bit sheds some light on the dilemma. Each flip-flop requires six transistors to store one bit of memory. Realistically, design constraints limit the number of reliable transistors easily manufactured on an IC.

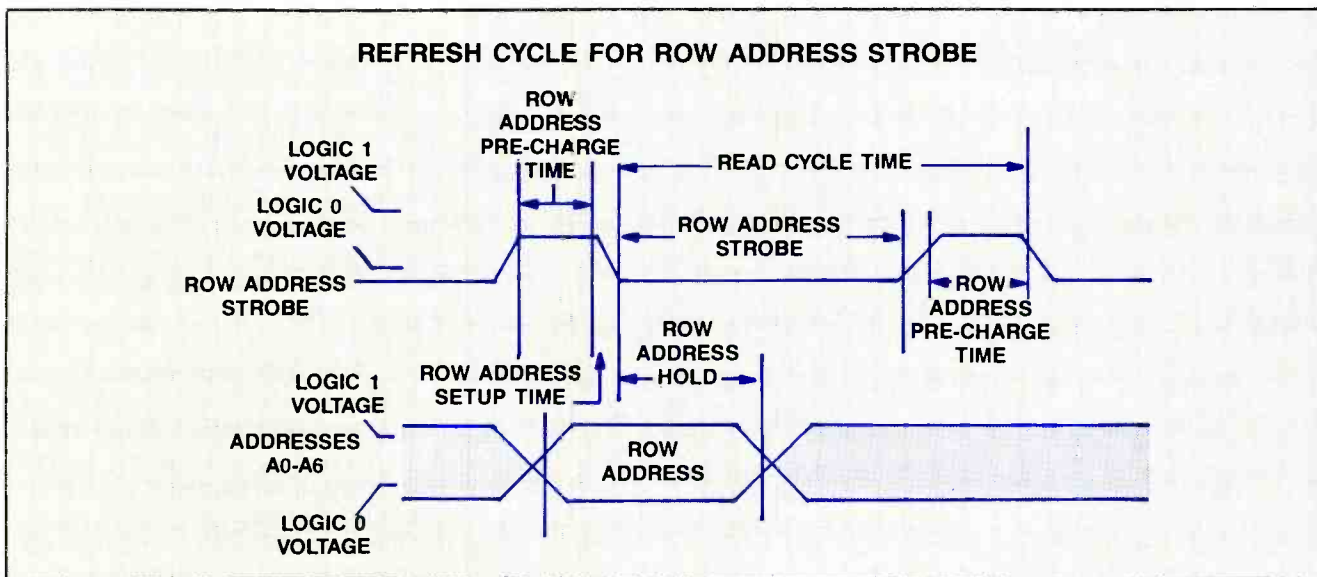

**Figure 2.** To compensate for the small amount of leakage current that a transistor switch would have and for the constant current drain that a capacitor features, a dynamic RAM constantly recharges the bit locations to keep the memory locations from losing their stored contents. By activating every location through the use of special signal lines, the inputs of the dynamic RAM refreshes the bit locations every few milliseconds.

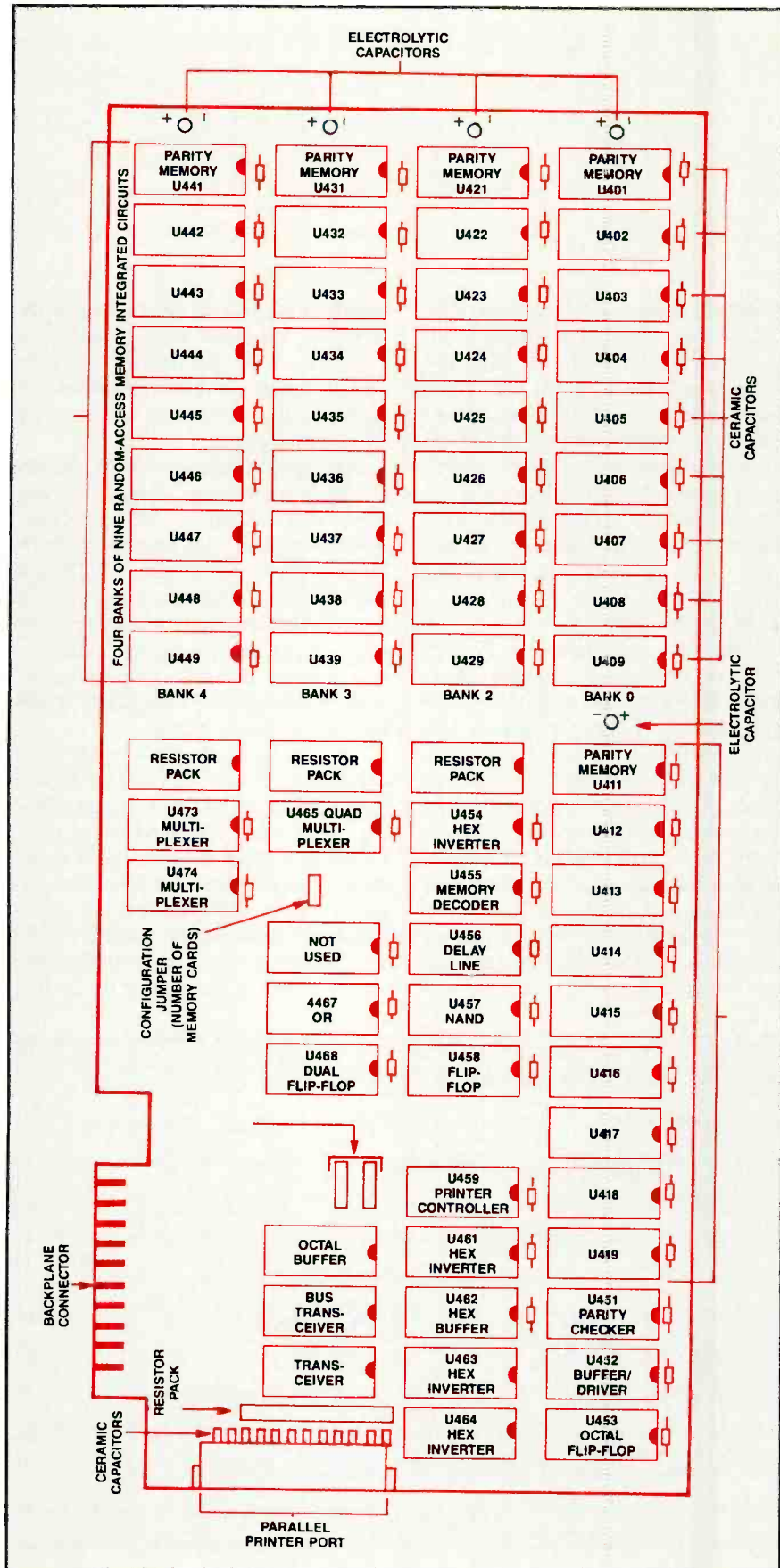

Figure 3. Although different configurations of memory cards or combination CPU/memory cards are used, the same transaction procedures exist.

Other, more effective methods exist. Another problem occurs with the use of large numbers of transistors to accommodate the flip-flop operations. As the static RAM gains size, the power consumption also begins to grow. Heat dissipation and the problem of providing the necessary power begin to affect the operation of the circuit.

The operation of dynamic RAMs is similar to that of static RAMs. If you look at the design of the dynamic RAM, simplified in Figure 1B, the real difference between the two devices becomes apparent. You can also see why the dynamic device is more efficient. Rather than using a flip-flop for a storage mechanism, one bit of a dynamic RAM consists of a single transistor and a ca-

---

**Early Zenith microcomputers use 64K memory devices; later versions use 256K memory devices. Installing the 256K devices will allow the user to place a full 640K of RAM on one card.**

---

pacitor constructed on the IC die. This use of fewer components per bit of RAM allows dynamic RAMs to store anywhere from 16K to 256K of memory and use much less power than the simple static RAM.

Early Zenith microcomputers use 64K memory devices; later versions use 256K memory devices. Installing the 256K devices will allow the user to place a full 640K of RAM on one card. Aside from replacing the memory decoder IC for a different program address logic, replacing the older 64K memory devices with 256K memory devices does not require any memory card modifications.

### Refreshing your memory

Data represented by an electrical charge of either a logic high or low becomes stored in the capacitor through the actions of the transistor and the capacitor. Transistor action either stores or removes the charge to and from the capacitor, which converts the stored bit to the logic high or low state. In turn, other circuit action reads the state of the capacitor back onto the data lines.

To compensate for the small amount



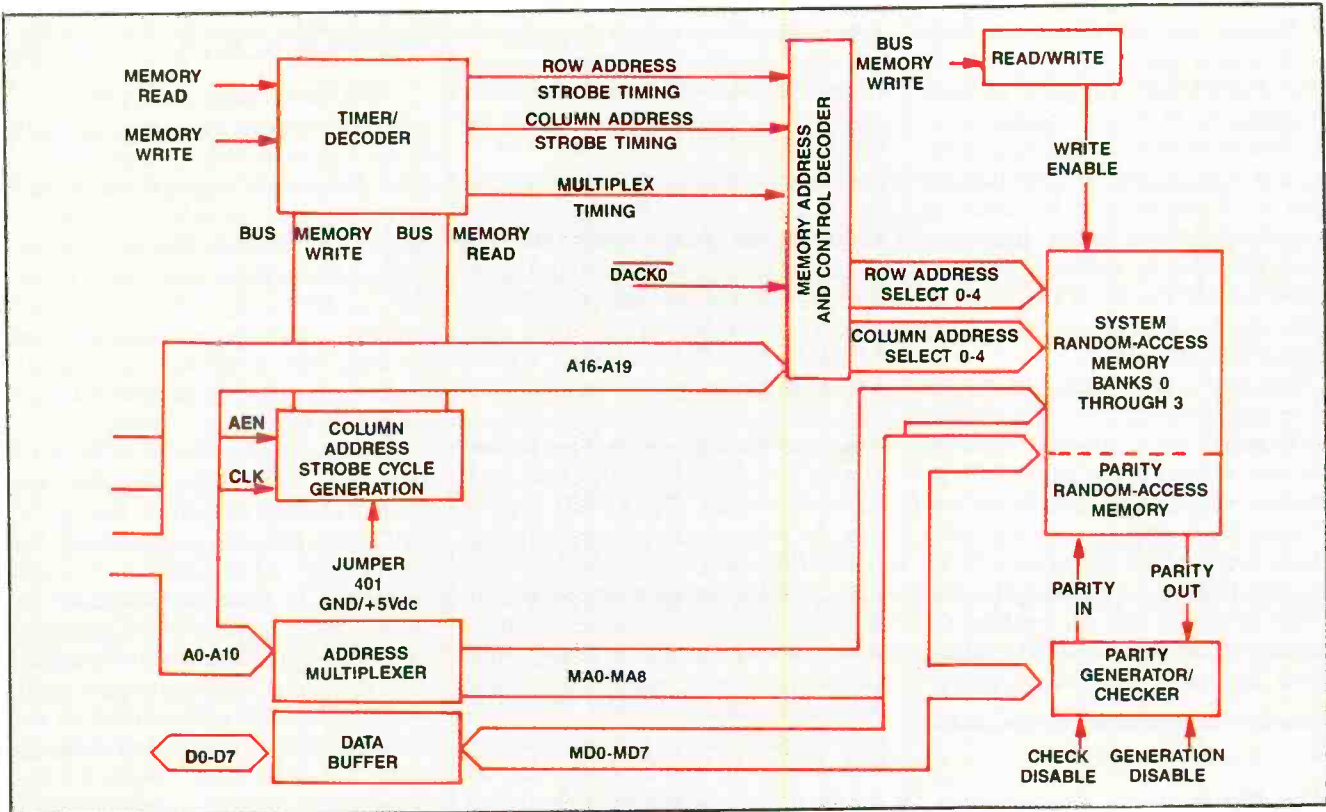

Figure 4. A typical flow chart of memory-access operation shows that many signals must be generated to access memory.

**Chempad™**  
IPA Saturated Cleaning Pad



**Twillwipes™**  
Lint-Free Cotton Wipers



**Ultrajet®**  
Precision Dusters

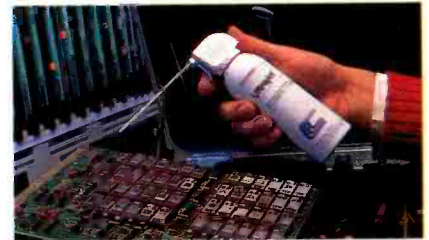

**Chemswab™**  
IPA Saturated Foam Swab

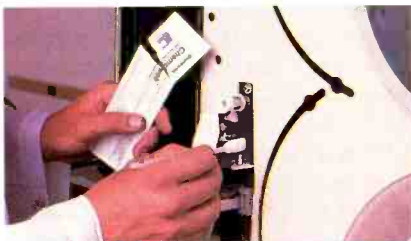

**Freez-It®**  
Tracks Thermal Intermittents

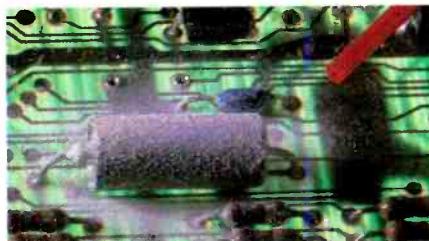

**Gold Guard™**  
Preserves Metal Contacts



**Performance you can count on.**

The electronic service industry's most popular chemicals and cleaning products for over 30 years. Call or write today for a free catalog, samples or technical assistance.



Chemtronics Inc. 681 Old Willets Path, Hauppauge, NY 11788 800-645-5244 in NY 516-582-3322

Circle (12) on Reply Card

of leakage current that a transistor switch would have and for the constant current drain that a capacitor features, a dynamic RAM device must have some way to refresh its memory locations every few milliseconds. Without the constant recharging of the bit locations, the memory locations would lose their stored contents. By activating every location through the use of special signal lines, the inputs of the dynamic RAM refresh the bit locations.

This may seem trivial, but for the technician, it is important. Because the bit locations are constantly refreshed, the values found at the inputs will not remain constant indefinitely. If you look at these points with an oscilloscope or a logic probe, you'll find signal activity associated with these refresh cycles even if the processor has not enabled the writing or reading process. The refresh signal happens on-chip and automatical-

---

**On the surface, the process of accessing memory seems overwhelming because of the many signals that are generated during the operation.**

---

ly every 16.4 microseconds. (See Figure 2.) If a memory read or write operation occurs at the same time as the refresh cycle, the read or write operation will receive priority.

#### **Read/write operation**

A transaction begins when the processor indicates the address of the designated bit group on the address line and announces that it will read from or write to the specific memory location by using a read-write line called *write-enable*. Although the memory forms the basis for the circuitry, other support circuitry, used for timing and control access, plays an important role in the transaction. Even though Zenith relies on different configurations of memory cards (shown in Figure 3) or the combination CPU/memory card (shown in Part III in the September issue), the same transaction procedures exist. Looking at the signals on the Zenith backplane and on the control bus, you'll find that only the three signals called MEMW (memory write), MEMR (memory read) and IRQ0 (re-

fresh request) can initiate the memory-access cycle. Another signal, the address-enable or AEN signal, must also exist for the other signals to start the cycle.

On the surface, the process of accessing memory seems overwhelming because of the many signals that are generated during the operation. Figure 4 shows a typical flow chart of memory-access operation. Aside from the MEMW, MEMR and IRQ0 signals found on the backplane, the operation also requires the timer/encoder section, which generates the row-address strobe-timing (RASTIM) signals, the multiplex-timing (MUXTIM) signals and the column-address strobe-timing (CASTIM) signals. Each of these signals provides timing relationships for selecting the correct memory address. Also, another signal, the RAM-select (RAMSEL) signal, allows parity error generation and data transfer. The bank-select signal (RAS) and the column-address signal (CAS) are generated during the column-address and row-address sequence. ROWADRS\*, the row-address signal, is generated during the memory-refresh cycle. This signal designates the eight least-significant address bits as the refresh address for the RAMs. During the multiplexing sequence, the ROWADRS\* signal also provides the column address for the RAM.

The bus memory-read (BMEMR) and bus memory-write (BMEMW) signals appear during the respective read or write operations. With the action of these signals, data is transferred between the input/output bus and the memory. A signal called DIROUT\* (direction in/out) establishes the direction that the data travels. Interaction between the user, the microcomputer and any attached peripheral devices affects the transfer. The memory section supplies parallel data from the microcomputer to a parallel device, such as a printer. The printer then sends status signals back to the microcomputer.

Because of the complexity found in the memory section, we will take a more probing look at the actual signal functions and operations in Part V of this series. We will look at the individual ICs that Zenith uses in its 150 series of microcomputers, and we'll examine the evolution of memory circuitry throughout the series. Finally, we will explore the problems and solutions that occur in the memory sections of the Zenith microcomputers. ■

## Feedback

### **Finding replacement parts**

My compliments to you and your staff on the August 1989 issue. Your articles show that you do hear and understand the problems of the electronics servicing professional. I was pleased to see the "Replacement Parts Showcase." It is a start at addressing our number one problem — finding a parts supplier for the many brands we service. I would like to see the western suppliers take advantage of this special format.

I was interested in the information in the article, "New-Technology Survival Guide." I recently received, for repair, a VCR with bar code programming. To say the least, I was totally lost on the circuit and so were the technicians in shops in the area. Even after I procured a service manual, I still did not understand the circuit. I have now purchased a book by John D. Lenk, which does explain the circuit and troubleshooting tricks. The point is, as long as the engineers and designers keep throwing new circuits at us even before we learn to service the old one, we will have to have a continuing education program. I suppose we will all survive as long as there are technical writers who understand the circuits and magazines like *ES&T*.

*Your letter reflects the comments we get most often from our readers — two major problems faced by electronics servicers are finding parts and servicing information, and keeping up with new technologies. We hope the replacement parts showcase will continue to grow and improve, offering our readers a handy comparison of parts suppliers and the special features they offer to help our readers choose the right supplier. (If you're stumped on finding any supplier of parts for a particular brand of consumer electronics product, write to us and we'll see if the new Information Exchange department can help.)*

*Keeping up with technology is imperative, and it isn't going to get any easier. With new advances looming on the horizon — such as HDTV, home automation, DAT recorders and the latest TV designs — electronics servicing will continue to require a real dedication to learning your business, and relearning it when new information is developed. Technicians who have the dedication to keep up should do just fine in surviving the new technologies. — Editor*

# Answers to the quiz

Questions are on page 8.

These answers illustrate some of the basic, important rules of Boolean algebra. Also, some of the circuits are used in logic systems.

• Circuit number two is used as a buffer. An OR gate can be used instead of the AND gate to get the same result because  $A + \bar{A} = 1$ .

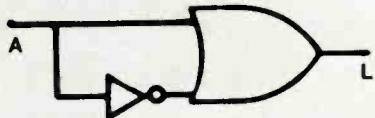

1.  $A + \bar{A} = 1$

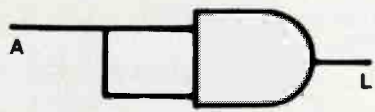

2.  $A \times A = A$

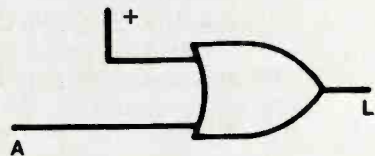

3.  $A + 1 = 1$

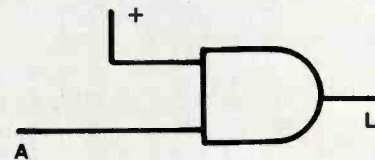

4.  $A \times 1 = A$

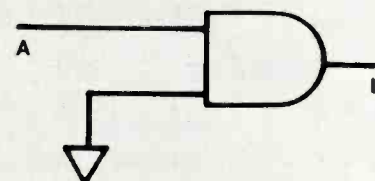

5.  $A \times 0 = 0$

• Circuit number four can be used as an ENABLE if a switch is connected into the + line. A signal passes through only when the switch is closed.

• Circuits number eight and nine are examples of the use of De Morgan's rules.

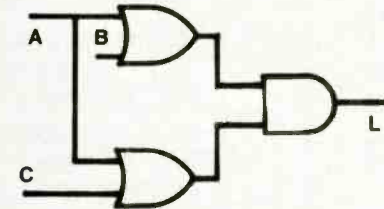

6.  $(A + B)(A + C) = A + BC$

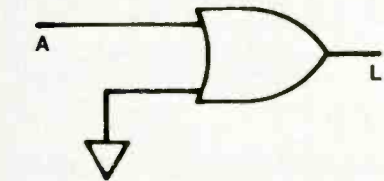

7.  $A + 0 = A$

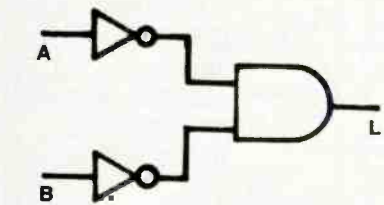

8.  $\overline{A B} = \overline{A + B}$

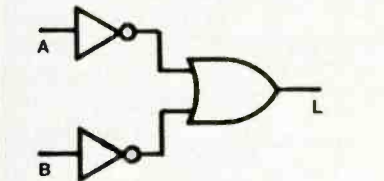

9.  $\overline{A + B} = \overline{A} \overline{B}$

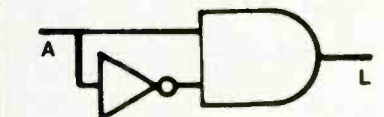

10.  $\overline{\overline{A}} = A$



## VCR ALIGNMENT TAPE

This professionally mastered 15 minute alignment tape will prove to be an important addition to your repair equipment inventory. It will assist in the adjustment of the tape path and audio/control head alignment, head switching point, luminance and chroma circuit, and tracking fix. 30 Hz audio tone, gray raster, NTSC color bars, convergence grid and convergence dots. Great for TV alignment also.



#505-030

\$24<sup>95</sup>

## BATTERY ELIMINATOR

This handy adaptor eliminates the need for batteries when using your camcorder in your automobile. Simply insert the "dummy" battery pack into the camcorder and the lighter plug into the cigarette lighter jack of the vehicle. Your camcorder then draws its power from the car's electrical system. The lighter plug has a built-in 7 amp fuse to protect your camcorder from harmful current surges. Will replace our battery # 140-541. Call for more details.



#090-920

\$14<sup>90</sup>

## VCR IDLER KIT

Make VCR tire repairs quickly by having the tire you need in stock when you need it. This comprehensive kit contains 170 of the most commonly used tires in an easy-to-use case and a cross reference with over 80 manufacturer assembly numbers crossing to over 200 VCR model numbers. A \$400.00 retail value.



#400-900

\$55<sup>00</sup>

## VCR REPAIR PARTS KIT

Now you can do most of your VCR repair jobs the same day. Parts Express' VCR Parts Kit makes this possible. It contains over 45 of the most commonly used parts to repair RCA, Hitachi, Fisher, Sanyo, Lloyds, Panasonic, Sony, Sharp, JVC, Samsung, TMK, GE, Magnavox and more. Idler assemblies, pinch roller, sensing transistors, switches, and lamps are included in this comprehensive kit. You also save over \$20.00 (wholesale pricing). Call for more details.



#400-950

\$89<sup>95</sup>

FREE CATALOG



CALL TOLL FREE  
1-800-338-0531

340 E. First St., Dayton, OH 45402  
Local: 1-513-222-0173

Circle (15) on Reply Card

**VCR Model Cross Reference and Parts Cross Reference; ISCET; 256 pages; \$33 plus \$3 postage and shipping (update: \$5 plus shipping).**

This cross-reference guide, available from the International Society of Certified Electronics Technicians (ISCET), allows servicers to match service literature or parts presently in inventory. Brands covered by the cross-reference include Panasonic, Quasar, GE, Magnavox, Philco, Canon, Sylvania, Curtis Mathes, JCPenney and RCA. A 15-page update is also available. The update lists newer models of the brands listed in the cross-reference guide, plus it includes a few models from Hitachi, JVC, Teknika and Goldstar.

ISCET, 2708 W. Berry St., Fort Worth, TX 76109; 817-921-9101.

**1989 IC Master, 16th edition; Hearst Business Communications; \$140 plus \$10 shipping and handling.**

This updated, 3-volume reference set includes 12,000 new ICs and more than 150,000 alternate source devices. Volume one is a guide to more than 80,000 standard ICs, including 12,000 new devices, plus an application note directory and a military section. Volume two covers technical data, with more than 1,200 manufacturer data pages and a manufacturer and distributor directory. Volume three is a systems level volume that describes custom and semicustom ICs, CAE and CAD design tools and microprocessor boards.

Hearst Business Communications, 645 Stewart Ave., Garden City, NY 11530; 516-227-1300.

**IBM Personal Computer Troubleshooting & Repair for the IBM PC, PC/XT and PC AT, by Robert C. Brenner; Howard W. Sams; 400 pages; \$24.95.**

This manual, intended as a combination tutorial and reference book, uses block diagrams, charts, photographs and tables to explain what the computer does and how it works. Instructions on how to specify, isolate and correct most PC-XT-AT failures are provided. The book describes system operation of the three models; basic and advanced troubleshooting techniques, including specific procedures for the PC, PC/XT and PC AT; and error indicators.

Howard W. Sams, 4300 W. 62nd St., Indianapolis, IN 46268; 317-298-5604.

## PHOTOFACT

**AOC**  
2678-1 ..... AC2034C/CA  
(CH. M9C5-8D/-8D3)  
2680-1 ..... AC1434C/CA  
(CH. M3C5-8D/-8D3)

**Hitachi**  
2674-1 ..... CT1386B/W  
2675-1 ..... CT2085B/W  
2677-1 ..... CT2079  
2679-1 ..... CT2075W  
2686-1 ..... CT7880B/K, CT7886K,  
CT7890K

**JCPenney**  
2659-1 ..... 685-2288-00 (855-3893)  
2666-1 ..... 685-4120-00(855-9866),  
685-4130-00(855-3695)  
2684-1 ..... 685-2299-00 (855-3679)

**JVC**  
2662-1 ..... AV2058S  
2663-1 ..... C-1328

**Magnavox**  
2666-2 ..... CJ4146WA01/21,  
EMX852PE01/02/21,  
EMX862A01/02/21,  
EMX862MY01/02/21,  
EMX862PE01/02/21,  
RJ4250WA01/02/21  
(CH. 19E101/02/05/09,  
19E401/02/05/09)

2668-1 ..... CJ4130WA01  
2671-1 ..... EMK872AK01/  
872BK01/872MY01/  
872PE01/882BK01/  
882BK02/882PE01/  
882PE02, RJ4320WA01/  
4324CH01/4330WA01/  
4330WA02/4334CH01/  
4340WA01/4344CH01/  
4348CH01/4349WA01  
(CH. 20F101/102/104/  
105/108/109)

2672-1 ..... CJ3922CH01/02  
2676-1 ..... CJ4712AK01/  
4714HP01/R716PE01,  
RH4558AK01, RJ4484AK01/  
4488CH01/4812AK01/  
4814HP01/4816PE01/  
5540AK01/5542CH01/  
6020AK01/6024AK01/  
6026PE01 (CH. 25G102/  
103/105, 26G101, 27G101)  
2683-1 ..... CJ3922CH03

## Mitsubishi

2669-1 ..... CK-2602R, CS-2656R

## Panasonic

2662-2 ..... WT5931WH  
2668-2 ..... CTK-2085S,  
PC-21S85S (CH. AEDP167,  
YAEDP167)  
2670-1 ..... CTK-2052R,  
CTK-2053R, PC-21S54R  
(CH. ADP165/GL7H,  
YADP165/GL7H)  
2671-2 ..... CTG-2085  
(CH. NMX-GZ1)  
2673-1 ..... CTK-2780S  
(CH. AEDP150)  
2690-1 ..... CTK-2063S,  
CTK2068S, CTK2073S,  
PC-21S64S (CH. AEDP165,  
ALEDP165, YEDP165)

## Philco

2657-2 .. 25C802-00AA/CC/GG/HH,  
25C803-00AA/BB/CC,  
25C805-00AA/BB/CC,  
25C819-00AA/BB/CC,  
26C801-00AA/CC/EE/FF/KK,  
26C802-00AA/BB/CC,  
26C803-00AA/BB/CC,  
26C810-00AA/BB/CC,  
26C811-00AA/BB/CC,  
26C812-00AA/BB/CC,  
26C813-00AA/BB/CC/DD,  
26C815-00AA/BB/CC/EE/FF,  
26C818-00AA/BB/CC

## Quasar

2656-1 ..... TU9880CW  
(CH. ADC148/GL7S)  
2657-1 ..... WT5931W/BW-1  
(CH. MC151/S1, LC151/S1)  
2660-1 ..... TU9811CU,  
TU9818CP, TL9839CP  
(CH. ADC142/GL7S)  
2665-2 ..... TL9971CK, TL9978CK  
2682-1 ..... WPI310DW (CH. C191/S1)

## RCA

2658-1 ..... FPR471T-1,  
FPR473B-1/B-2, FPR477E-1,  
FPR500W-1/W-2/W-3,  
FPR505W-1/W-2/W-3,  
FPR510WR-3, FPR515WR-3,  
FXR425E-1/E-2,  
FXR469ER-1/ER-2,  
FXR469WR-1/WR-2,  
820515AK-1, AK-2  
(CH. CTC136D/E/F/J/  
P/R/T/AA/AB/AC/AD)  
2665-2 ..... FPR520WR-1,

FPR710TR-1, FX620WR-1,  
 GPR790T-1, GPR791T-1,  
 GPR794-1, GPR795FR-1,  
 GPR798P-1, GPR799PR-1,  
 GPR821TR-1, GPR823TR-1,  
 GPR825TR-1, GPR841PR-1,  
 GPR845H-1, GPR849PR-1,  
 GXR640T-1, GXR648P-1,  
 GXR651TR-1, GXR659PR-1,  
 JPR920ER-1/DR-1/HR-1/WR-1,  
 JPR922WR-2, JPR980WR-1  
 (CH. CTC130A)  
 2669-2 ..... FPR550WR-1,  
 FPR555WR-1, FPR560ER-1,  
 FPR566TR-1, FPR570TR-1,  
 FPR577ER-1, FPR722WR-1,  
 FPR722TR-1, FPR725ER-1  
 (CH. CTC130B/C)  
 2681-1 ..... FMR520WR/  
 535WR/536ER/552ER/  
 618E/620WR/622TR/623ER/710TR,  
 GMR640T/641TR/644H/  
 645HR/648P/649PR/  
 651TR/655HR/659PR/810P/  
 811PR/814H/814L/815HR/  
 815LR/818P/819PR/820T/  
 821TR/822T/823TR/825TR/  
 830P/831PR/833PR/841TR/  
 843ER/845FR/849PR,  
 JMR920DR/920ER/920NR/  
 920TR/920WR/920YR/922WR/  
 926WR/980WR/984WR  
 (CH. CT130A)  
 2687-1 ..... JPR950W-1/2/3,  
 JPR960HR-3/WR-1/WR-2/  
 WR-3/YR-1, JPR962WR-1/2/3,  
 JPR966WR-1/2/3, JPR966YR-2,  
 JPR968AR-1/BR-2/ER-2/HR-2/  
 R-1/TR-1/WR-1/WR-2/WR-3  
 (CH. 136M/N/U/W)

**Sears**  
 2658-2 ..... 564.40432850  
 2659-2 ..... 564.48208850/51  
 2667-1 ..... 580.42031850  
 2685-1 ..... 564.42353850/51  
 2686-2 ..... 580.42003750  
 2688-1 ..... 564.42312850  
 2690-2 ..... 564.48892850

**Sharp**  
 2664-1 ..... 13NV68 (BK)/(GY)  
 2673-2 ..... 19NP48  
 2676-2 ..... 25NV88  
 2677-2 ..... 19NV68(BK)/(GY)  
 2678-2 ..... 25NC178  
 2679-2 ..... 20NV78(BK)  
 2680-2 ..... 25NC288  
 2681-2 ..... 25NT58  
 2682-2 ..... 13NM48

2683-2 ..... 25NV68(BK)/(GY)  
 2684-2 ..... 19NV88  
 2685-2 ..... 20NV68(BK)  
 2688-2 ..... 25NC168  
 2689-1 ..... 25NT18  
  
**Sony**  
 2661-1 ..... KV-20TX10/11/12  
 (CH. SCC-B55D-A,

SCC-A50K-A, SCC-B55E-A/J-A)  
 2667-2 ..... KV-27SXR10/11  
 (CH. SCC-595I-A,  
 SCC-607H-A, SCC-595J)

**Sylvania**  
 2656-2 ..... CL8122AK01,  
 CL8124HP01, CL8126AK01,  
*Continued on page 43.*

## Power Disturbances? BMI PowerScopes help you solve them.

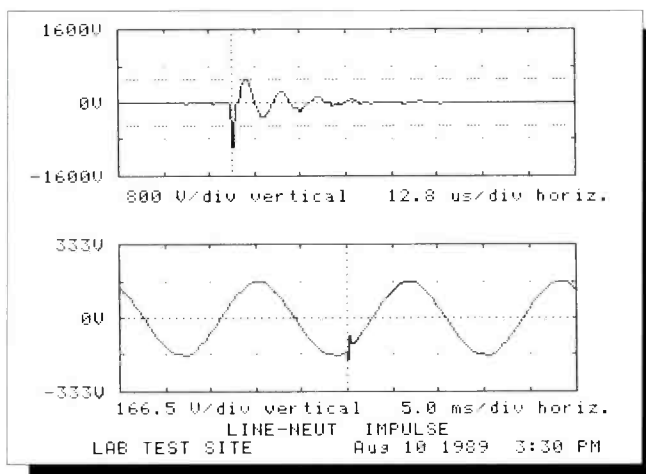

### A Complete Power Line Monitor.

BMI's PowerScopes graph your power problems. Problems such as sags, surges, impulses, and waveshape faults. And, PowerScopes monitor DC, single-, and three-phase power at a range of 45 to 450 Hz.

PowerScopes can also monitor and report on harmonics and environmental factors, store your data on disk, and send/receive data via modem. Harmonic reports include both THD and a complete spectral analysis.

The PowerScope from BMI is designed for accurate measuring, clear reporting, fast response, and ease of use. It provides you with clear, easy to read graphs of the measurements take. These graphs make it easy to pinpoint problems and make reliable decisions to improve your power quality.

**Call today for a brochure, or to set up a demonstration.**

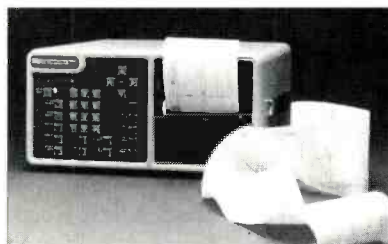

**BMI** Basic Measuring Instruments  
 335 Lakeside Drive  
 Foster City, CA 94404  
 Tel. 415 570-5355  
 Fax 415 574-2176

**1-800 876-5355**

Circle (26) on Reply Card

# Focus on facsimile

By Roger McCarty

Although facsimile (fax) machines have been around for many years, they have just recently generated a surge of interest among owners of business and personal users alike. Why this sudden rise in popularity?

The primary reason for this surge of interest is that the user has direct control over the communication process. Fax communication is efficient — it eliminates mail delays, such as delivery lag-times associated with regular mail and even express services, or telephone time wasters, such as being placed on

free, unless there are difficulties in the transmission or defects in the transceiver itself, of course.

For companies that depend heavily on fax communication, a malfunction must be repaired immediately, but that can be a problem. After all, do *you* know a fax technician? And who's qualified to perform these repairs? Now is a good time to strongly consider present and future fax servicing opportunities.

## The fundamentals of fax

Initially, fax technology may appear

supply) that must be understood to effectively service the machine. (See Figure 1.)

- The *document scanner* is responsible for scanning the document to be transmitted and creating an electrical signal that represents the information on the document.

The document is scanned in a precise, line-by-line process using three major sub-assemblies located in the document scanner. (See Figure 2.) The light source floods the printed line with light. The light reflected from the paper will vary with intensity in direct proportion to the print density: a high-intensity reflected light for those areas that are white, a low reflected intensity from areas containing print. A fiber-optics assembly captures this modulated light and then transfers it to an optical transducer, in this case a CCD (charge-coupled device), which ultimately creates the signal to be processed by the next functional block: the transmission image processor.

- The *transmission image processor* manipulates the signal from the document scanner into a form that is universally compatible with any other fax transceiver. One example of signals that are necessary in assuring compatibility is the addition of motor control signals necessary to synchronize the motors and other mechanical functions within the transceiver. This circuitry also ensures that the transmitted data will adhere to standards established by the Consultative Committee of International Telephone and Telegraph (CCITT) for Group 3 fax standards. (See the sidebar, "Basic CCITT Specifications.")

- The *data transmission system* receives the signal from the transmission image processor. The data transmission system may also be referred to as a modem (modulator/demodulator). The purpose of the modem is to modulate the data from the transmission image processor into a form that can be contained within the bandwidth limits of 300Hz to 3.1kHz imposed by the standard telephone line. In the receive mode, the

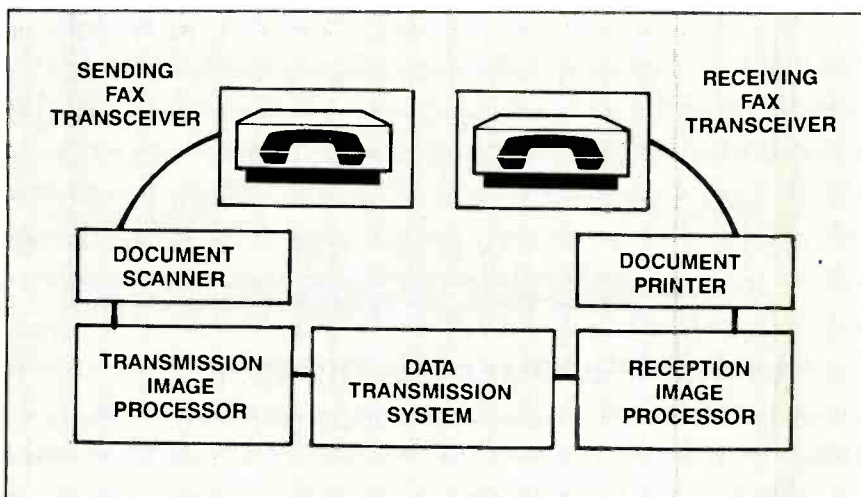

Figure 1. To get the information from one fax machine to another, the transmission goes through five functional blocks.

hold or playing endless games of telephone tag. What's more, fax virtually eliminates misunderstandings and misinterpretations by instantly delivering to the receiving fax machine a duplicate copy (facsimile) of the original communication.

Fax transmission is direct, ignoring differences in time zones or absent recipients, and it completely bypasses the middle man commonly associated with all other types of written communications. In short, fax communication is fast, reliable, inexpensive and error-

to be intimidating. After all, the circuitry seems to bear little resemblance to the more familiar consumer electronics circuitry. The components are similar, nonetheless. The primary difference is that the circuits are configured differently to conform to the processing requirements of signals that are peculiar to fax transmission and reception. Diagnosis and troubleshooting can be easily accomplished using conventional test equipment and the "divide and conquer" technique, once the technician has become fully familiar with the fax equipment and methods of transmission.

A fax transceiver can be divided into five functional blocks (plus the power

McCarty is a technical adviser in the Technical Services Division at Mitsubishi Electric Sales America.

## Basic CCITT specifications – G2 and G3 fax transceivers

International standards for fax are formulated by the Consultative Committee on International Telephone and Telegraph, the CCITT. This agency is part of the International Telecommunications Union (ITU), a United Nations agency.

### G2 (Group 2)\*

Input document size . . . . . ISO A-4 size (8.25"×11.7")  
 Scan line length . . . . . 205mm (8.1 inch)  
 Pixels per line . . . . . not applicable (analog system)  
 Scanning density . . . . . 3.85 lines/mm (98 lines/inch)  
 Transmission rate . . . . . 360 lines/minute  
 Transmission system . . . . . analog: amplitude modulation  
 Document transfer . . . . . A-4 sized document in three minutes

\*Standard established in 1976, Amended in 1980

(Complete specifications may be found in "CCITT Recommendation T.3 – Standardization of Group 2 Facsimile Apparatus for Document Transmission – Orange Book," Volume 7, Rec. T.3: ITU, Geneva, 1980.)

### G3 (Group 3)\*

Input document size . . . . . ISO A-4 size (8.25"×11.7"); (optional): ISO B-4 size (10.1"×14.0") ISO A-3 size (11.7"×16.6")  
 Scan line length . . . . . 205mm (8.1 inches)  
 Pixels per line . . . . . 1,728 pixels on an 8.25-inch line optional: 2,048 pixels on a 10.1-inch line; 2,432 pixels on a 11.7-inch line  
 Scanning density . . . . . normal: 3.85 lines/mm (98 lines/inch) fine (optional): 7.7 lines/mm (196 lines/inch)  
 Transmission rate . . . . . variable, depends on image density  
 Digital coding . . . . . MH (modified Hoffman, line length); MR (modified read, page length)

Sidebar continued on page 42.

# Absolutely, positively, overnight.



## All Makes/All Models. Exact Replacement Parts Overnight!

▶ Thousands of quality brand name modules, tuners, and VCR exact replacement parts are in stock at PTS. Call toll free before 2:00 pm and we'll ship today! And PTS saves you up to 30% off manufacturer's list price. Order today and have your part tomorrow! Just say "Charge it!"

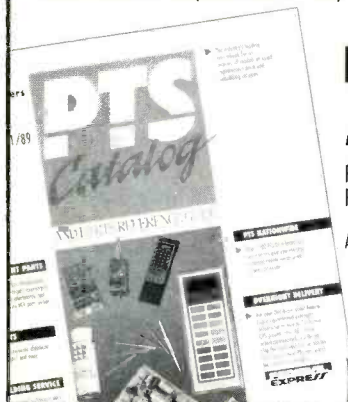

**TRY PTS TODAY • CALL TOLL FREE!**

## 1-800-333-PTS-1

PTS Corporate Headquarters  
 P.O. Box 272, Bloomington, IN 47402



Arvada CO • Bloomington IN • Longview TX • Tampa FL • Schenectady NY

◀ FREE Catalog! Compare our prices. Industry's most complete module listing and cross reference guide. Plus details on VCR, Camcorder, TVRO, SMATV and Microwave rebuilding services. More!

Circle (13) on Reply Card

October 1989 *Electronic Servicing & Technology* 41

## Basic CCITT specifications

(continued from page 41.)

Transmission system . . . . . digital:  
quad phase modulation  
Document transfer . . . . . A-4 sized  
document in one minute  
\*Standard established in 1980.

(Complete specifications may be found in "CCITT Recommendation T.4 — Standardization of Group 3 Facsimile Apparatus for Document Transmission — Orange Book," Volume 7.2, Rec. T.4: ITU, Geneva, 1982.)

Here is a rough, non-technical translation of the major provisions of the CCITT standards for fax.

The Consultative Committee of International Telephone and Telegraph

(CCITT) has established standards to which all manufacturers of fax machines must adhere. Currently, Group 3 standards represent the current technology available for use on the standard public telephone line. To achieve communication between two separate fax machines, both machines must support the same group of standards. Some Group 3 machines do possess the capability of falling back to Group 2 standards.

### Group 2

- AM analog process
- transmission speed fixed to two to three minutes per page
- AM signals are sensitive to line conditions

• fair to poor copy quality is now uncommon (copy quality limited by scanning resolution; low speed limits usage to medium volume)

### Group 3

- digital technology permits high image quality
- high-quality documents in 20 to 40 seconds per page
- high-speed facilitates use in high-volume locations
- digital technology best for error-free, long-distance transmissions
- additional features: time/day/date stamp, transmitter identification stamp, transmission verification, auto speed select

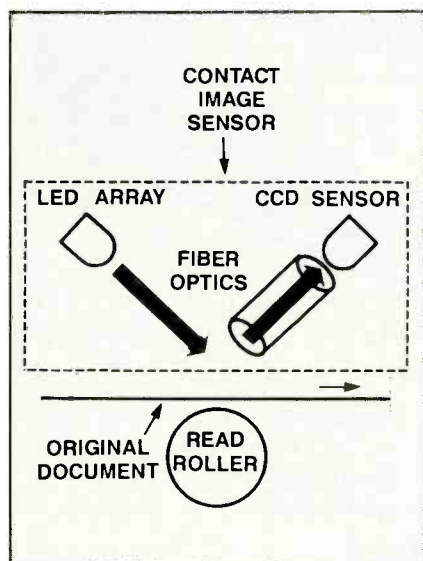

**Figure 2.** The light source floods the printed line with light, which is then captured by a fiber optics assembly and transferred to an optical transducer.

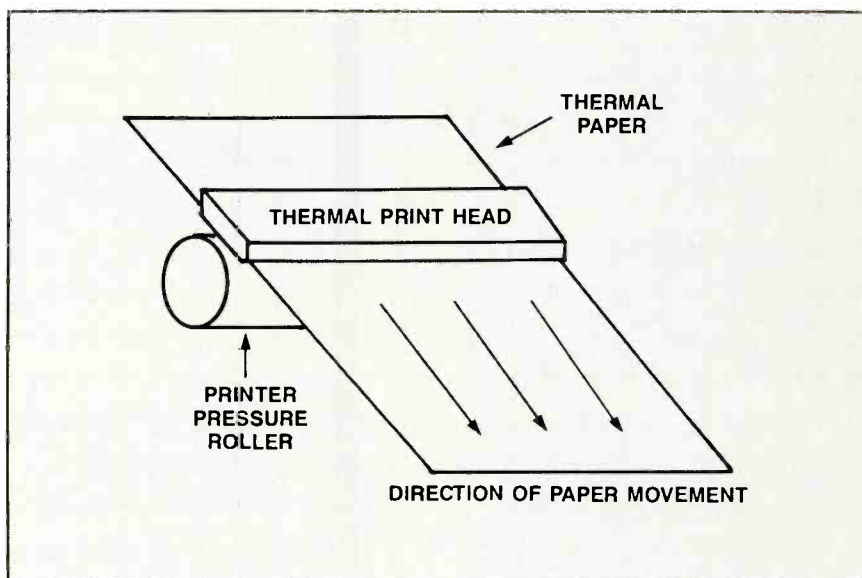

**Figure 3.** A thermal printer supplies a current, modulated by the information to be printed on the document, to individual resistor elements that are in contact with the paper. As the resistor elements heat up, the chemically treated paper turns black at the point of contact.

modem demodulates the information detected from the telephone line back to the original data form.

• The *reception image processor* receives the signal from the data transmission system. This functional block is charged with the task of returning the data signal to the original document form before manipulation by the transmission image processor. Part of this process includes the extraction of the control signals used to drive the motors in the receiving fax machine. The result-

ing document information signal is then coupled to the document printer.

• The *document printer* used by most fax machine manufacturers is a thermal printer. A thermal printer operates by supplying a current, modulated by the information to be printed on the document, to individual resistor elements that are in contact with the paper. As these resistor elements heat up, the chemically treated paper will turn black at the point of contact. This process occurs using the same line-by-line format

as the document scanner. (See Figure 3.)

To efficiently diagnose and repair fax problems, you need to understand the concepts of operation as presented here. You should also understand the communication process and telecommunication equipment problems.

Hands-on fax seminars are available to teach the principles of fax and the methods of transmission, along with specialized diagnosis and troubleshooting techniques. This training is also available on videotape. ■



CL8129PE01, CLD206WA01,  
 CLD251AK01, CLD253AK01,  
 CLD255PE01, CLD257PE01/02,  
 CLE822AK01, CLE824HP01,  
 CLE826AK01, CLS251AK0/02/03/04,  
 CLS253AK01/02/03/04,  
 CLS255PE01/02/03/04,  
 CLS262AK01/02/03/04,  
 CLS268PE01/02/03/04  
 (CH. 25C502/05/12/29/38/58)  
 2660-2 ..... CLE251AK01/02/03,  
 CLE253PN01/02/03,  
 CLE255PE01/02/03,  
 CNE272AK01/02, RLE351AK01,  
 RLE353PN01, RLE355PE01,  
 RLE357PE01, RLE358AK01/02,  
 RLE362AK01/02,  
 RLE368PE01/02/03,  
 RNE372AK01/02,  
 RNE375PN01/02, RNE378PE01/02,  
 RNE590SL01, RNE592BK01,  
 RNE595AK01, RNE602CH02/03/04,  
 RNE602SL01/02/03/04,  
 RNE980AK01, RNE982PE01,  
 PNF480AK01/02, RNF482AK01/02,  
 RNF486PE01/02, RNF612CH01,  
 RPF590AK01, RPF592BK01,

RPF598PE01, RPF702AK01  
 (CH. 25C604/05/08,  
 26C604/05/09/10/11/16/18,  
 27C602/03)  
 2664-2 ..... RL9122AK01,  
 RL9124HP01, RL9126AK01,  
 RL9129PE01, RLD308WA01,  
 RLD335PE01/02, RLD338AK01/02,  
 RLD342AK01/02, RLD344HP01/02,  
 RLD346PE01/02, RLD351AK01,  
 RLD352AK01, RLD353AK01,  
 RLD354AK01,  
 RLD355PE01/02/03/04,  
 RLD356PE01, RLD357PE01/02,  
 RLD359PE01/02/03/04,  
 RLE305WA01/02/03/04,  
 RLE308WA01, RLE335PE01/02,  
 RLE338AK01, RLE342AK01,  
 RLE344AK01, RLE346PE01,  
 RLE650WA01, RLE652PE01,  
 RLE922AK01, RLE924HP01,  
 RLE926AK01, RLF335PC01,  
 RLF650PC01, RLF652PC01,  
 RLS351AK01/02, RLS355PE01/02,  
 RLS362AK01/02/03/04,  
 RLS368PE01/02/03/04  
 (CH. 25C501/04/07/10/26/

27/28/30/37/44/45/57/59)  
 2687-2 ..... CLF235PE01/2,  
 CLF242AK01/2 (CH. 25C811/813)  
 2689-2 ..... RLF308WA01/2/3,  
 RLF335PE01/2, RNF337PE01/2/3,  
 RNF338AK01/2/3, RNF352AK01/2/3,  
 RNF354HP01/2/3, RNF356PE01/2/3,  
 RNF601WA01/2, RNF921AK01/2/3,  
 RNF922PE01/2/3, RNF924HP01/2/3,  
 RNF926AK01/2/3  
 (CH. 25C809/818, 26C807/817)

**Toshiba**  
 2670-2 ..... CF2758, CX2958C  
 (CH. TAC8820, TAC8825)  
 2672-2 ..... CX2778, CX2978C  
 (CH. TAC8823/27)  
 2674-2 ..... CX2788, CX2988C  
 (CH. TAC8824/28)  
 2675-2 ..... CF2678, CX2968C  
 (CH. TAC8821/26)

**Zenith**  
 2661-2 ..... DI308S, V3309W  
 2663-2 ..... DI312W/82W,  
 SD1327W/W3/Y/Y3,  
 SD3321S/37S/61S ■

## A Special Offer from MSC!



Limited Time Offer!  
**\$89.95**

Plus shipping and handling

### The Compact Disc Theory & Servicing Program at a Compact Price!

Regularly a \$99.95 value, The Compact Disc Theory and Servicing Program is available for a limited time at the special price of \$89.95. Housed in an attractive binder, it includes a 107-minute training videotape featuring *The Basics of Compact Disc* and a 148-page book, titled *Compact Disc Troubleshooting and Repair*. It is a comprehensive training tool, covering both the operation and troubleshooting of CD players, and will be a valuable addition to your technical library.

Available in VHS NTSC format only.

Yes, I wish to order the PR-04 Compact Disc Theory & Servicing Program at this special price! I have enclosed a check or money order for \$93.95 to cover the cost of the program plus shipping and handling.

Please send me a free copy of your latest Training Materials Catalog.

Name \_\_\_\_\_ Company \_\_\_\_\_

Address \_\_\_\_\_

City \_\_\_\_\_ State \_\_\_\_\_ Zip \_\_\_\_\_

Hurry! Sale ends November 30, 1989  
 New Jersey residents please add \$5.40 N.J. state sales tax.



Service is our middle name!

Matsushita Services Company TAS/Publications 2B-6  
 50 Meadowland Parkway Secaucus, N.J. 07094  
 Division of Matsushita Electric Corporation of America

**Panasonic Technics Quasar**

Circle (14) on Reply Card

# PRODUCT PREVIEW



### Current and open tracers

Identifying, locating or tracing computer cables can consume many frustrating and costly manhours. Amprobe Pas-sar's Current Tracer and Open Tracer are two effective and efficient solutions to this problem. The tracers allow the electrician to trace computer cables quickly, safely, easily, whether they are connected, within bundles, under raised computer floors, inside metal conduit or cable trays or behind concrete walls.

Circle (75) on Reply Card



### Scope 3 1/2-digit LCD meter

The DVM 630 measures dc and ac voltage and resistance, performs battery and diode testing with  $\pm 0.5\%$  accuracy, and has automatic negative polarity and zero adjustment. The meter is overload protected and includes test leads. Regularly \$50, now \$32.50 (deluxe carry case only \$4.50). FREE catalog with your order. Call Fordham at 800-645-9518 (NYS 800-832-1446).

Circle (78) on Reply Card



### Training materials for Panasonic, Technics and Quasar

Matsushita Services Company offers many training manuals, videotapes and video-based programs for various audio, video, home appliance products and more. Although they are produced mainly for Panasonic, Technics and Quasar products, they are also useful for learning theory and troubleshooting for other brands.

Circle (81) on Reply Card



### Introducing the PowerProfiler

The 3030 PowerProfiler from BMI is a simple yet powerful instrument capable of measuring and describing all aspects of your power consumption. It can report on the power in use for a single load or an entire facility. Use it to trace and eliminate power guzzlers or track down potentially harmful harmonic problems.

Circle (76) on Reply Card



### Oscilloscopes

Heath's SO-4552 (\$599.95) and SO-4554 (\$399.95) oscilloscopes are dependable and versatile tools that feature dual trace, 1mV/cm maximum sensitivity, algebraic add function, beam finder, built-in component tester, and high-brightness mesh CRT with internal graticule. The SO-4554 includes a 40MHz bandwidth and fast 9ns vertical rise time. The SO-4552 has a 25MHz bandwidth and an 18ns vertical rise time.

Circle (79) on Reply Card



### Computer programming training from NRI

Build a high-paying career, even a profitable business of your own, in computer programming. NRI's new at-home training includes a powerful IBM-compatible computer, modem and professional software in BASIC, Pascal, C and COBOL, yours to keep. FREE full-color catalog tells more. NRI School of Computer Programming, 4401 Connecticut Ave. N.W., Washington, DC 20008.

Circle (82) on Reply Card



### Environmentally safe chemicals

Chemtronics has introduced a line of E-Series chemicals that outperform conventional ozone-depleting CFCs (chlorofluorocarbons). Ultrajet is a high-powered precision duster; Freez-it locates thermal intermittents faster; Flux-Off Plus removes flux more effectively than other leading brands; and TF Plus is environmentally safer and stronger than conventional TF solvents. For more information: Chemtronics, 681 Old Willets Path, Hauppauge, NY 11788; 800-645-5244; 516-582-3322.

Circle (77) on Reply Card



### Multiformat video/all RF channel generator

The new model 408 from Leader Instruments is a gen-lockable NTSC video test signal generator that provides more than 80 test patterns. Test signals are output in composite, component, super VHS and RGB formats. Up to 100 sets of video level specifications and channel frequencies can be stored. On-screen programming and a menu-driven format make setup fast and easy.

Circle (80) on Reply Card

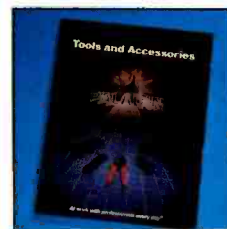

### Catalog of hand tools and accessories

A new, 4-color catalog is being offered by Paladin, the leader in hand tools and accessories. This 152-page catalog displays state-of-the-art products required for any application. From wire strippers, crimpers and cutters to coax connectors, screwdrivers and wire ferrules, Paladin provides it all. Quality products backed up by quality service...Paladin is "at work with professionals every day."

Circle (83) on Reply Card

# PRODUCT PREVIEW



### Portable PanaVise

The weighted base mount (five pounds) means you can move this PanaVise with ease! The self-centering, extra-wide opening head (opens a full nine inches) and full (tilt, turn and rotate) capabilities make this a truly portable, versatile addition to any workbench. PanaVise model 334. Available through electronics suppliers or PanaVise Products, Inc., 2850 E. 29th St., Long Beach, CA 90806.

Circle (84) on Reply Card



### Free replacement parts catalog

The new catalog from PTS is the most comprehensive inventory of TV and VCR exact replacement parts. All makes of tuners, modules, plus motherboards are listed. Order direct and save! New services: disc drive, VCR and camcorder repair. More! Overnight delivery. 800-333-7871.

Circle (87) on Reply Card

### PC diagnostics made easy!

PC-Technician from Windsor Technologies, Inc., is a complete family of products for faster, easier troubleshooting of all types of IBM-compatible PCs. It's an easy-to-use yet professional level system that gives you an extremely wide range of specific tests for each PC component.

Find out why the number of PC-Technician users is growing so fast. Send for your FREE evaluation diskette.

Circle (90) on Reply Card

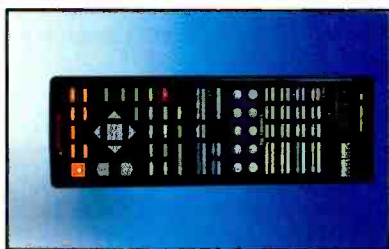

### A truly universal computerized remote

Parts Express introduces a programmable, hand-held IR remote control to replace all others. Imagine, one remote to operate your CD player, laser disc, DAT, TV, VCR, tape deck, amplifier and surround sound amp. Controls up to eight devices. "Learns" and reproduces up to 126 commands. Call 800-338-0531 for more information.

Circle (85) on Reply Card



### Audio troubleshooter

The PA81 from Sencore is an audio troubleshooter that replaces homemade test centers with certified tests. Non-reactive loads test power to 250W/channel. Filters isolate interference. Finds intermittents while protecting circuits. Exclusive 3-way tracer pinpoints trouble, even in low-level stages. Battery operated, too.

Circle (88) on Reply Card

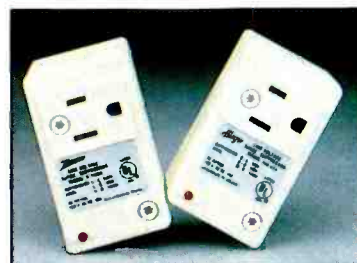

### Spark Gap surge suppressor

Zenith's new surge suppressor features the patented Spark Gap design for extra protection of TVs, VCRs, stereos, computers and modems from the damaging effects of high-voltage power surges. Also available as part of the Allegro audio/video accessory line. Zenith Parts and Accessories, 11000 Seymour Ave., Franklin Park, IL 60131.

Circle (91) on Reply Card



### Surge suppressors

Philips ECG offers a complete line of surge suppressors that protect valuable equipment against damaging transient voltage spikes in a variety of industrial, commercial and residential applications. The line includes power outlet strips, general-purpose 1-, 2- and 3-outlet models, and a master power control with four auxiliary outlets. Shown here (left to right) are the EMF-515MC Master Power Control and the EMF615RF and EMF615 power outlet strips.

Circle (86) on Reply Card

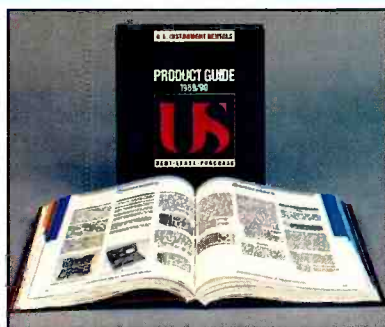

### FREE 1990-91 catalog

NEW EDITION ON PRESS! Comprehensive 384-page guide packed with more than 5,000 products from 170 manufacturers, with photos and unbiased comparison charts. Free! U.S. Instrument Rentals, 1830 W. Airfield Drive, DFW Airport, TX 75261; 800-USIR-123.

Circle (89) on Reply Card

# REPRINTS

Interested in ordering article reprints out of this or another issue? \* Reprints can be excellent learning tools for your technical staff and great marketing tools for your sales staff. Call or write Kelly Hawthorne at Intertec Publishing Corp., P.O. Box 12901, Overland Park, KS 66212; (913) 888-4664.

\* Minimum order 500 copies.

# What do you know about electronics?

## The turbo tweaker

By Sam Wilson, CET

Recently I looked in my references to review some easy methods of designing a transistor amplifier. I haven't needed to do that for more than a year, so I thought I'd see if there might be a new (better) method.

I found many quick methods, but none were turbo, as mine is. (Why do I call it turbo? Haven't you noticed? No one uses terms like "quick" and "fast" these days; everything is turbo.) I didn't feel that any of those methods were any better (or worse) than mine, so we might as well use mine.

With my method, you only need a few basics (such as Ohm's law), and you have to tweak the calculated result. Keep in mind that this is only one method of estimating values for an amplifier. What you do to improve it will complicate it.

You have to start with basic ideas. (The entries are for my example design.) Refer to Figure 1.

Wilson is the electronics theory consultant for ES&T.

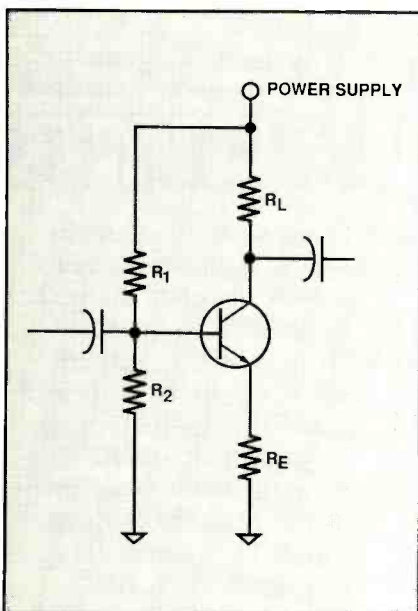

**Figure 1.** With this easy method of designing a transistor amplifier, you only need a few basics, such as Ohm's law. You have to tweak the calculated result.

- What power supply voltage do you have?  $V_{cc}=24$
- What transistor are you going to use?  $2N2222$

These aren't listed in the order of selection. I bought 15 transistors in a pack for \$2. That's how I decided on the 2N2222. The specifications that came with my pack of transistors are given in Table 1.

Note that the collector-to-emitter voltage is given in Table 1 as 30V. I used a value lower than that because I am going to use a 24V supply that is made with four 6V lithium batteries.

The specifications show that the transistor is capable of a collector current of 0.8A. I don't need that much current for my design, and I have to consider the life of the batteries, so I'm going to go for a current of 50mA. Therefore,  $I_c=0.05A$ .

Here is an important difference between these quick designs and the kind

that engineers use. For the current I need, the 2N2222 is not the best choice. Because I want to use the inexpensive device that's available, however, I'm going with what I have on hand rather than with what I need.

The value of  $R_L$  can now be calculated using Ohm's law. Remember that in a Class A amplifier, the collector voltage ( $V_c$ ) should be half the supply voltage ( $V_{cc}$ ).

$$R_L = V_c / I_c = 12 / 0.05 = 240\Omega$$

I'll use a standard 270 $\Omega$  resistor. The power rating of this resistor is

$$P_L = (I_c)^2 \times R_L = (0.05)^2 \times 270 = \text{about } 0.7W$$

I have some 1W resistors. I'll use one of those.

The emitter voltage ( $V_E$ ) should be a convenient value between one-fifth and one-fourth the collector voltage. The collector and emitter currents are about the same. The emitter resistor value is easy to calculate:

$$R_E = V_E / I_c = 2.5 / 0.05 = 50\Omega$$

I'll use a 47 $\Omega$  resistor. Its power rating is:

$$P = (I_c)^2 \times R = (0.05)^2 \times 47 = 0.1W \text{ (approximately)}$$

A 0.25W resistor will do the job.

I always make  $I_2$ , the current through  $R_2$ , equal to at least one-tenth the value of the current that runs through  $R_E$ :  $I_2 = 0.05 / 10 = 0.005A$ .

As shown in Figure 2, the voltage across  $R_2$  equals the voltage across  $R_E$  plus the traditional drop from emitter to base:  $V_2 = V_E + V_{E-B} = 2.5V + 0.7V = 3.2V$ . By Ohm's law:

$$R_2 = V_2 / I_2 = 3.2 / 0.005 = 640\Omega$$

A standard resistor of 620 $\Omega$  will do

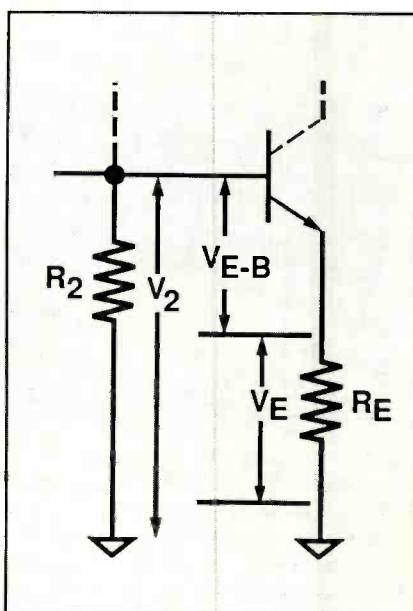

**Figure 2.** The voltage across  $R_2$  equals the voltage across  $R_E$  plus the traditional drop from emitter to base:  $V_2 = V_E + V_{E-B}$ . By Ohm's law,  $R_2 = V_2 / I_2$ .

here. The power dissipation is:

$$P_2 = (I_2)^2 \times R_2 = (0.005)^2 \times (620) = 0.015W$$

Use whatever you have. Note that I used the calculated value for  $R_2$ . Figure 3 shows that the current through  $R_1$  is equal to the sum of the base current and  $I_2$ .

Although the spec sheet gives 200 for beta ( $h_{FE}$ ), a more realistic value is 150. Because  $h_{FE} = I_C / I_B$ , you can calculate  $I_B$ :

$$I_B = I_C / h_{FE} = 0.05A / 150 = 0.00033A$$

$I_1$ , the current through  $R_1$ , can be found by adding the base current and the current through  $R_2$  ( $I_2$ ):

$$I_1 = I_2 + I_B = 0.005 + 0.00033 = 0.0053A$$

The voltage across  $R_1$  equals the power supply voltage minus the base voltage ( $V_2$ ):

$$V_1 = V_{CC} - V_2 = 24 - 3.2 = 20.8V$$

The value of  $R_1$  is found by Ohm's law:

**Table 1**  
**Transistor specifications**

276-1617	2N2222
silicon	NPN
typical $h_{FE}$	200
max. ratings:	
$V_{CE}$	30V
$I_C$	800mA
dissipation	1.8W

$$R_1 = V_1 / I_1 = 20.8 / 0.0053 = 3.9k\Omega$$

(approximately)

If you connected the circuit with the

calculated and assumed values, it would have the values shown in Figure 4.

You should not expect this design to give perfect results the first time out of the barn. Here are a few reasons why:

- The manufacturers say the beta ( $h_{FE}$ ) is somewhere between 150 and 300. That is the average according to four different sources. That can make a difference.
- The resistors have a tolerance of  $\pm 10\%$ .
- Some of the values were rounded off.
- Some of the resistor values were obtained by taking the closest off-the-shelf value.
- There was some guessing going on.

So, we now enter into the tweeker part of the design. The value of  $R_1$  is divided into two separate values as shown in Figure 5. As a rule, the middle-resistance value of the pot should be somewhere near to a resistance that adds to  $R_a$  to give the calculated resistance of  $R_1$ . I am using a linear pot in my design, so I'm about halfway between the ends and my starting point.

Adjust the resistor so that the voltmeter reads half the supply voltage. If

# ...THE REST OF US NEED A PANAVISE.

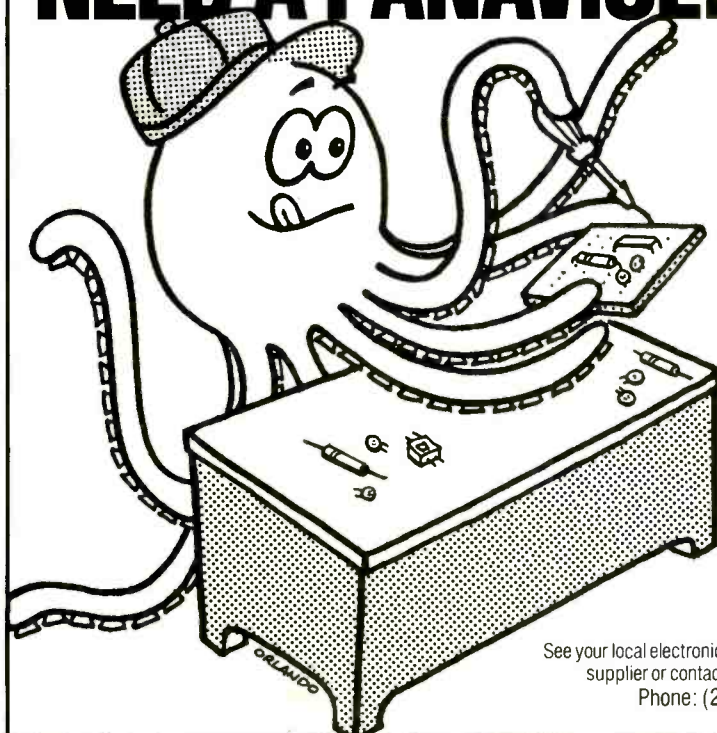

**STARTER KIT**—The perfect introduction to PanaVise! Two heads (Standard and Wide Opening) interchange with our "tilt, turn and rotate" Standard Base. Versatile quality for all your electronics projects. Ask for Model #302.

**CIRCUIT BOARD HOLDER**—Tilt, turn and rotate circuit boards to the exact position you want, then lock them into place with a single control knob! Moves work in vertical, horizontal or circular planes (perfect for front/back examination). Spring-loaded arm holds boards up to 12" wide. Ask for Model #372.

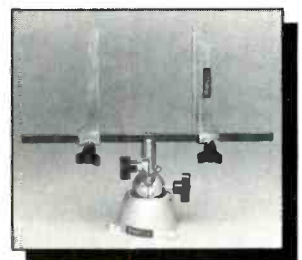

**PORTABLE PANAVISE WITH EXTRA-WIDE OPENING HEAD**—The weighted base mount (5 lbs.) means you can move this PanaVise with ease! The Self-Centering Extra-Wide Opening Head (opens a full 9") and full "tilt, turn and rotate" capabilities make this a truly portable, versatile addition to any workbench. Ask for Model #334.

See your local electronics supplier or contact:

**PANAVISE**<sup>®</sup>  
Phone: (213) 595-7621 Fax: (213) 595-9539

PanaVise Products, Inc.  
2850 E. 29th Street  
Long Beach, CA 90806

Circle (27) on Reply Card

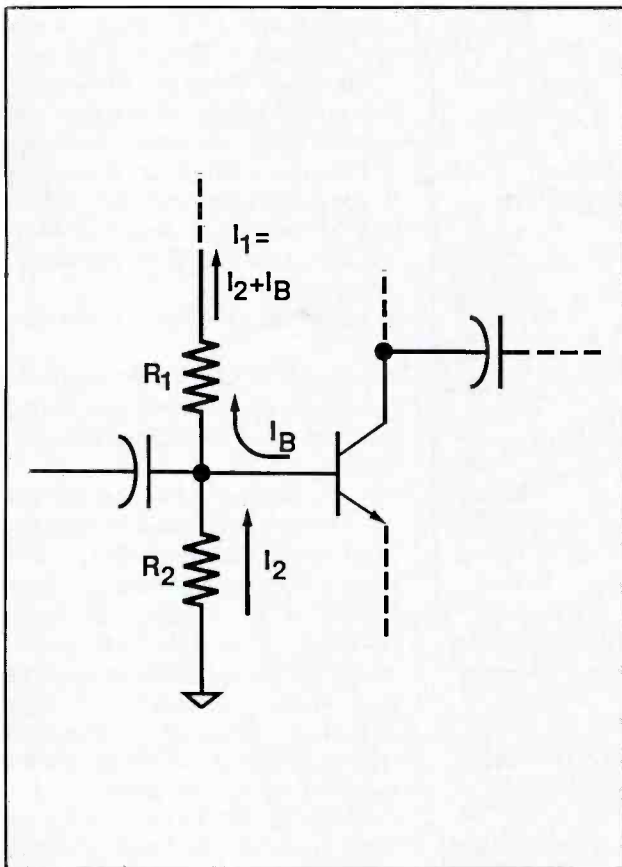

**Figure 3.** The current through  $R_1$  is equal to the sum of the base current and  $I_2$ .

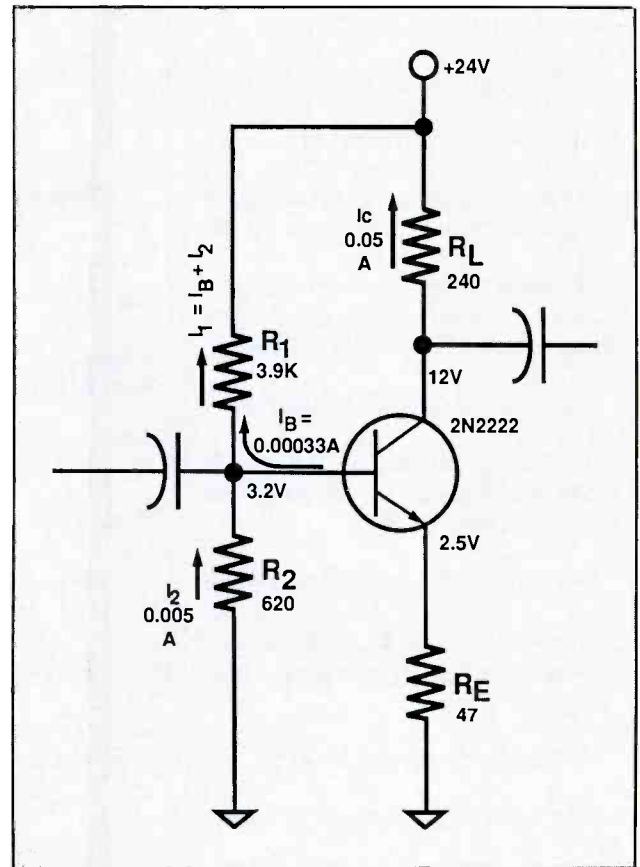

**Figure 4.** If you connected the circuit with the calculated and assumed values, it would have these values. However, this design will not give perfect results, so some tweaking is required.

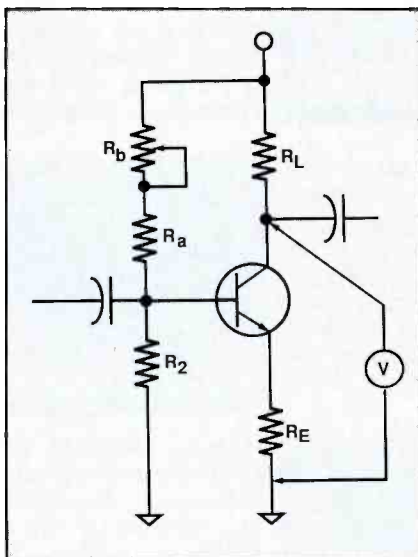

**Figure 5.** The value of  $R_1$  is divided into two separate values. As a rule, the middle-resistance value of the pot should be somewhere near to a resistance that adds to  $R_a$  to give the calculated resistance of  $R_1$  in Figure 4. Adjust the resistor so that the voltmeter reads half the supply voltage. Measure the total value of  $R_a$  plus  $R_b$  with an ohmmeter. Replace this total resistance with a standard resistor that has the closest value to this measurement for  $R_1$ .

it is below that value, you need more resistance. (The transistor is conducting too much collector current, so you want to decrease the base current. That means a higher resistance.)

If the collector voltage is above the value of  $V_{CC}/2$ , the transistor isn't conducting hard enough (there isn't enough voltage drop across  $R_a$  and  $R_b$ ). Therefore, you need to reduce the setting of  $R$  to get more base current. That, in turn, will raise the collector current and lower the collector voltage.

If you can't get the right value, analyze the situation. You will need either more or less base resistance for  $R_a$ . Return  $R_b$  to the center value and change  $R_a$ . Don't change it more than about a quarter of your starting value.

After you have tweaked the setting for  $R_a$ , measure the total value of  $R_a$  plus  $R_b$  with an ohmmeter. Replace this total resistance with a standard resistor that has the closest value to this measurement for  $R_1$  (in Figure 4).

If you are not satisfied with the amount of gain, increase it by bypassing the emitter resistor with an electrolytic capacitor. Keep in mind that

increasing the gain will produce two effects that may be undesirable:

- The bandwidth will be decreased.
- The distortion will be increased.

I built the circuit and did some first-class tweaking. I couldn't quite get the right collector voltage because the beta of my transistor was less than 200. Also, the load resistor was getting too hot for my way of thinking.

I changed the load resistance to 410Ω by putting two 820Ω resistors in parallel. They ran much cooler. I put two 100Ω resistors in parallel for  $R_E$  to get cooler operation there as well.

The overall result was to reduce the collector current to 38mA. After those changes, I was able to get the adjustment. However, I had to go to the end of the pot to do it, so I used a 6.2kΩ for the base resistance.

I let it run for two days. The voltage gain was nothing to write home about, but I was able to control a lot of current. Power amplifiers (and medium-power amplifiers) traditionally have a low voltage gain.

As far as I'm concerned, this thing runs smoother than a Tonka truck. ■

# Troubleshooting Tips

**Symptom: Poor vertical lock  
Sharp 19H74  
Photofact 2266-3**

The problem with this set was poor vertical lock, almost as if there were only a hairline on the vertical hold control where it would hold.

I started troubleshooting by checking the condition of the two output transistors, all electrolytics and all resistors in the vertical circuitry. Next I measured all of the voltages at the leads of transistors and IC1801. I checked the few vertical hold components to pin 30 by substitution. When everything up to this point checked out OK, I used the oscilloscope to check waveforms of everything that could be a possible cause of the problem, including the sync section. None of these tests showed any indication of an abnormal condition, except that the waveform at pin 31 seemed to be slightly fuzzy and distorted.

Without any clear course of action to follow, I decided that the problem was

probably a faulty IC1801, so I replaced it. Unfortunately, when I turned the set back on, the problem was still there.

I put the set aside for a while as I mulled over the problem and tried to determine what might be wrong. By a happy coincidence, another Sharp set based on the same chip and circuitry was brought in with a minor problem. This gave me the chance to perform comparison tests in the vertical section. Most oscilloscope waveforms looked very similar at the same test points in both sets, except for the waveform at pin 31.

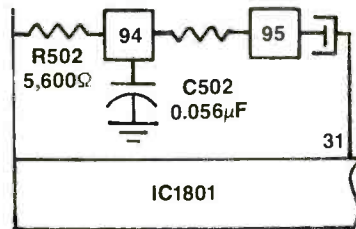

**Figure 1.** Comparison tests between two TVs provided the clue to this Sharp 19H74 with poor vertical lock.

This sync pulse waveform on the set with the vertical problem seemed distorted and fuzzy, while on the comparison set it was clean and sharp.

I performed a detailed analysis of the pin 31 waveform on the faulty set. When I set the oscilloscope's time base to 20μs, I was surprised to find that the vertical pulses were rich in pulses at the horizontal frequency as well, upsetting the proper operation of IC1801. Further close examination of the circuitry suggested that a likely cause of the problem would be one of the components in the R502-C502 low-pass filter — most likely C502. I bridged the suspected faulty capacitor with a known-good capacitor and was pleased to note that the fuzziness of the pin 31 waveform was eliminated. The waveform was sharp and clear. Normal operation of the set had also been restored.

A check of C502 with the capacitor tester verified that it was defective.

**Garbis Saatjian  
Los Angeles**



## Plug in!

### To the NESDA system.

**YOUR BUSINESS** is in the world's fastest changing industry. If you're not careful, you could find your business in the dark.

But, you don't have to stay there.

Through a system of local, state, and regional groups, the **National Electronics Sales & Service Dealers Assn. (NESDA)** keeps members up-to-date with the fast pace of advancing technology while offering:

- ◆ Managerial and technical training.
- ◆ Business contacts.
- ◆ Technical and management certification.
- ◆ Information on new products.
- ◆ Legislative activities that affect the industry.

Don't be left in the dark. Let the NESDA system work **FOR YOU!**

---

For more information and an application, write to:  
**NESDA, 2708 W. Berry St., Ft. Worth, TX 76109; Ph (817) 921-9061**

Name \_\_\_\_\_

Bus. Name \_\_\_\_\_

Address \_\_\_\_\_

State \_\_\_\_\_ Zip \_\_\_\_\_ Phone \_\_\_\_\_

Member of State  Local  Assn. \_\_\_\_\_

## MCM ELECTRONICS...

### *Nothing but the best!*

**THE BEST SERVICE**, including TOLL-FREE and FAX ordering, knowledgeable telephone representatives, fast order turnaround, and extremely flexible payment terms.

**THE BEST PRODUCT SELECTION**, with over 11,000 different items, including... semiconductors, connectors, audio and VCR parts and accessories, hardware, television parts, test equipment, chemicals, tools, and lots more!

**THE BEST ORDERING GUIDE**, MCM's FREE 180-page "powerhouse" catalog. It's organized for easy reference; and each edition includes hundreds of new products to make your work easier.

**For your FREE subscription to MCM's Catalog, call today!**

**TOLL-FREE  
1-800-543-4330**

**Only the best is good enough for MCM Customers like you!**





**MCM ELECTRONICS**  
 650 CONGRESS PARK DR.  
 CENTERVILLE, OH 45459-4072  
*A PREMIER Company*

**ES-48**

Circle (16) on Reply Card

# Keeping the CD laser pickup in focus

Because the optical pickup of a compact disc (CD) player doesn't have a nice, comfortable groove to ride in, as does the stylus of a turntable, the designers of the CD player have come up with an ingenious system of sensors and servos to keep the objective lens of the pickup at the right distance from the disc and at the center of the recorded track, consequently keeping the laser beam in focus.

### The beam splitter

The distance of the pickup from the surface of the disc — the *focus* — is controlled by a servo that has as its controlling input a signal from a multiple-element photodetector.

The laser light that impinges on the disc is transmitted through a beam splitter. The beam splitter allows the laser-generated light to pass directly through

to the disc surface, but once the light has been reflected from the disc surface, it causes the laser light to be reflected at right angles to the direction of the incident light and subsequently onto the surface of a photodetector. (See Figure 1.)

The signal generated by the light falling on the photodetector is used for two purposes: to create the audio signal and to control the focus of the laser beam on the disc surface. Here we'll only deal with the focusing function.

Notice that in Figure 1B, if the pickup is correctly focused, all of the light rays reflected from the surface of the disc are parallel. If the pickup objective lens is too near the disc, as in Figure 1A, the light rays from the disc diverge as they reflect from the reflecting surface of the beam splitter. If the pickup objective lens is too far from the disc, as in Figure 1C, the light rays coming

from the disc converge as they reflect from the reflecting surface of the beam splitter.

### Converting the light rays

The light rays reflecting from the reflecting surface of the beam splitter are passed through a combination lens that is made up of a convex lens and a cylindrical lens. (See Figure 2A.) If the rays leaving the reflecting surface of the beam splitter are parallel, which is the case if the beam is in correct focus, it falls in nearly a circular pattern on the center of the photodetector. (See Figure 2B.) Because of this pattern, approximately the same level of signal is generated at the outputs of each of the four segments.

The output of the photodetector is generated by combining the outputs of the individual segments diagonally:

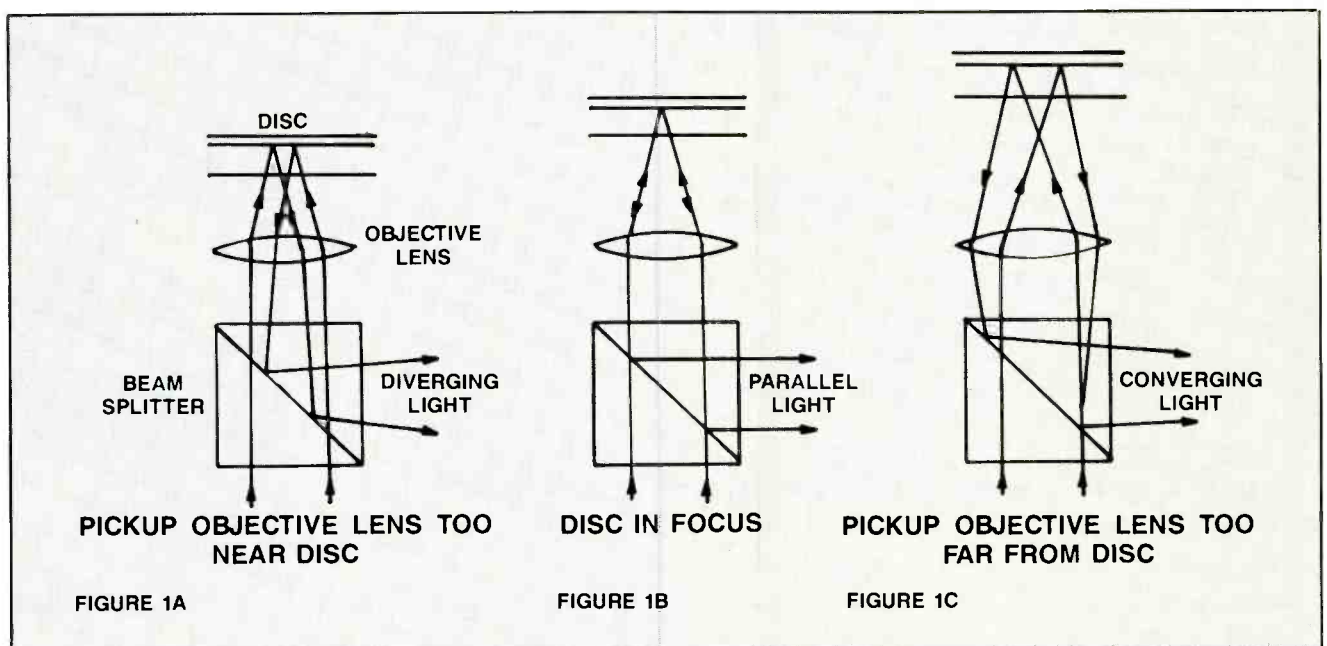
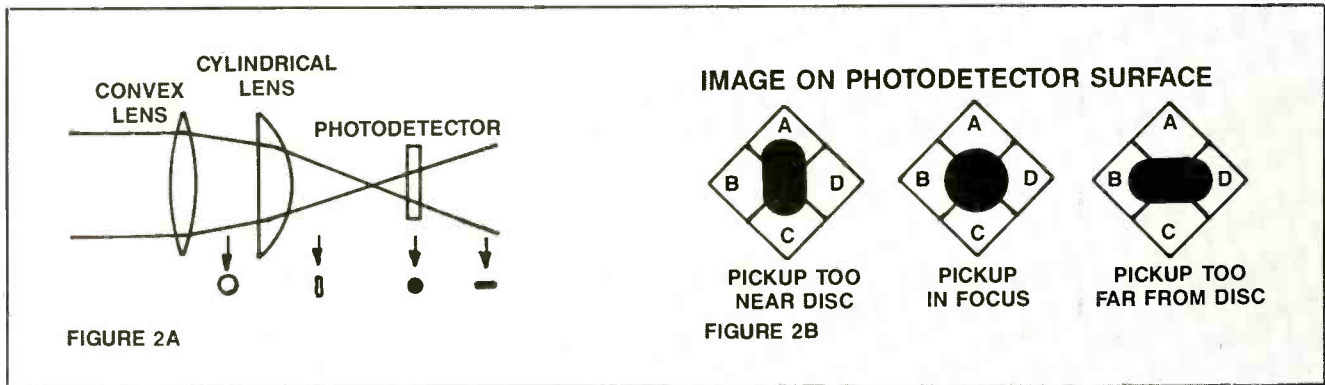

Figure 1. The laser pickup of a compact disc is kept in focus by a focusing servo. The error output to the servo depends on whether the objective lens of the pickup is at just the right distance from the disc, too near or too far.





**Figure 2.** The light reflected from the surface of the disc is passed through a combination lens consisting of a convex lens and a cylindrical lens. The photodetector converts this laser light into a focusing error signal.

photodetector output =  $(A + C) - (B + D)$

In the case where the pickup is in focus and, therefore, the outputs of all the segments are equal, the photodetector output, called the *focus error signal*, is zero.

If the pickup is too near the disc, the

amount of light falling on the A and C segments of the photodetector will be greater than the amount of light falling on the B and D segments. Therefore, the magnitude of the A and C output signals will be greater than the magnitude of the B and D output signals. This will cause a positive output signal from the

photodetector, which will cause the focus servo to move the pickup lens away from the disc.

On the other hand, if the lens is too far from the disc, the output from the photodetector will be negative, which will tell the focus servo to move it closer to the disc. ■

**Come Out of the Dark.**

If you're groping for a better method of running your business, let NESDA light your way with **Professional Electronics** magazine, only one of many "enlightening" benefits available to members of NESDA, the association of electronics sales and service dealers. For information about NESDA, and a sample issue of the magazine, just mail the following to NESDA:

Name \_\_\_\_\_  
 Address \_\_\_\_\_  
 City \_\_\_\_\_ State \_\_\_\_\_  
 Zip \_\_\_\_\_  
 Phone \_\_\_\_\_

National Electronics Sales & Service Dealers Association  
**NESDA**  
Service Dealers Association

2708 W. Berry St.  
 Ft. Worth TX 76109  
 (817) 921-9061

One of a Series

## Presenting an affordable Light Box System.



Model TR100 CB  
Camera Light Box  
with (2) transparencies

- (2) 3200° Kelvin Lamps (meets mfr. spec.)
- 1-year conditional guarantee
- Transparencies mounted in acrylic with optical scratch-resistant surface
- 11-step gray scale transparency
- 7-Bar color transparency
- All orders are shipped within 72 hours, U.P.S.

**\$799**

The method most manufacturers recommend

**NUTRONIX (313) 939-2740**

P.O. Box 77103 • Sterling Hts., MI 48077

Circle (17) on Reply Card

# Setting up a personal computer

By Glenn R. Patsch

The operation of a personal computer often can be improved by making a few simple changes to the way it is set up. Here are a few suggestions that you might be able to use after servicing a PC to improve its usefulness to the customer — after checking to see if he wants it done, of course.

## An ergonomic setup

After you find a place to put the keyboard, monitor and system unit and connect all the components, you have to plug the system into an ac outlet and test it all together.

If the system is an IBM XT or AT, you may want to move the unit off the desk or table and stand it up on end using a stand. I have made several of these for the XT, using a piece of 2×4 lumber. Cut two 1-foot pieces from the 2×4 and cut a notch 2¼ inches deep by ½ inch long in the wood (measure the height of the unit to be sure this is the correct dimension). See Figure 1 for an example.

If the keyboard and monitor cables are not long enough to reach the system unit, extension cables are available. Moving the system unit gives you a lot

Patsch is a consultant specializing in the selection, evaluation and installation of IBM PCs and compatible hardware and software.

more desk space and makes the unit seem quieter because the fan is farther away from the user. If you move the system unit to the floor, the monitor can sit on the desktop, making the monitor easier to see. A tilt swivel base for the monitor allows the user to move it for the best viewing angle.

## Why power protection?

Plug the system unit, video monitor, printer, external modem and other accessories into an ac plug strip with surge suppression. The power strip gives the user a single, convenient place to turn everything on and off. It also ensures that the printer or monitor won't be left on for long periods because they were not turned off when the computer was.

Another advantage to using a single plug strip is that it eliminates the problem of replacing the expensive internal power switches. These were known to fail with alarming regularity on the XT. It is a lot easier and less expensive to replace the plug strip than to replace the internal power switch. The surge suppressor, usually a metal-oxide varistor (MOV), saves the computer from most of the daily spikes that appear on the power line. I usually put the plug strip on the desk right behind the monitor to make it convenient to reach.

Look at where you are placing the system. Is it likely to get bumped while it is in use? If so, you will be adding wear and tear to the hard disk by risking scratches in the disk surface and loss of data. Is the monitor in a place that minimizes glare from sunlight and overhead lighting? Is the desktop at a convenient height for the user? If it is too high or too low, it will be awkward to use.

## Setting up the software

The way you set up the software for the system is just as important as how you set up the hardware. Create a directory for DOS and each application program you use. Make a directory using the MD command. Put a path command in the autoexec.bat file to make the applications easy to use. Here's one possibility for the config.sys file:

```
Files=20
Buffers=20
Break=ON
```

"Files" specifies the maximum number of files that can be open at the same time by a program. "Buffers" is used to improve reading information from a disk by storing the information read in a memory buffer. "Break=ON" checks

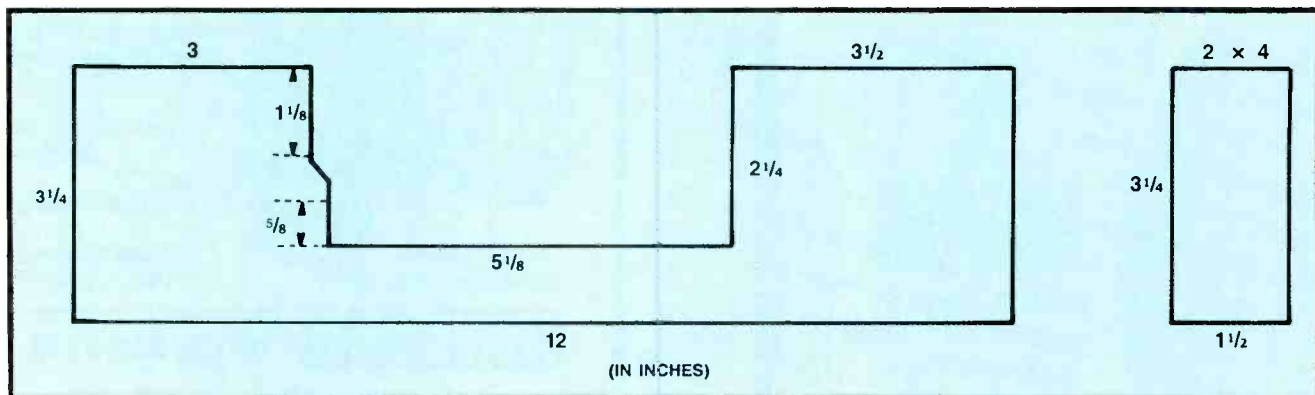

Figure 1. If the user would like to get his IBM XT or AT off the desk and out of the way, you can build this stand out of 2×4 lumber.

more frequently for the Ctrl-Break keys to exit a program.

You may have additional commands for ansi.sys, disk cache, special hardware devices, shell for command.com options, and stacks.

The above config.sys file is a good start. Setting the buffers will improve disk performance. Many systems now include a disk cache with the DOS software. In many cases the disk cache performs better with buffers set to a small amount, allowing the cache software to optimize disk usage. Check your specific cache software installation instructions. After you create or change a config.sys file, you must reboot the system using the Ctrl-Alt-Delete keys, or you can turn the power off and back on again, to make the change take effect.

Here's a suggestion for the autoexec.bat file:

```
ECHO OFF
PATH C: \ ; C: \ DOS; C: \ WORD;
C: \ BATFILES;
```

PROMPT \$P\$G  
CLS  
ECHO IBM PC/XT COMPUTER  
WITH EGA SCREEN

"ECHO OFF" causes the file not to type (echo) the commands on the screen as the batch file executes. "Path" specifies where the computer should search for commands or batch files that are not in the current directory. Notice when specifying the path that each directory to search is ended with a semicolon. The path command tells the computer to search the root directory first, then the DOS directory, the WORD directory and finally the BATFILES directory. Path can also be used to search different disk drives. "Prompt" controls the C: > prompt you see on the screen. The \$P causes the name of the current directory to be displayed, and the \$G causes the > to follow. The last command is an echo that displays the name of the computer. I often add this so people know what type of computer they are

using. This command is especially useful when several people share a computer.

Keeping everything organized by directory also makes it easier to upgrade to a new version of a program. Try to avoid putting a lot of files in the root directory. The root should contain command.com, autoexec.bat and config.sys files. DOS should be in a separate directory. I usually create a batfiles directory to keep all the batch files separate and place this directory in the path. If you have utilities available, such as Norton and Mace, let the user know that if he finds his hard disk drive performance slowing down as it becomes full of information, you can speed it up for him using the unfragment routines from these programs.

By making some changes in the way a PC is set up, you can often improve it. When you service or upgrade a PC, you can add value by checking both the software and the hardware to see whether changes might improve it. ■

**LEARN VCR**  
**CLEANING/MAINTENANCE/REPAIR**  
EARN UP TO \$1000 A WEEK, WORKING PART TIME FROM YOUR OWN HOME!



Secrets Revealed!  
NO Special Tools or Equipment Needed.

**EARN UP TO \$60 AN HOUR AND MORE!**

THE MONEYMAKING OPPORTUNITY OF THE 1990's

IF you are able to work with common small hand tools, and are familiar with basic electronics (i.e. able to use voltmeter, understand DC electronics)...

IF you possess average mechanical ability, and have a VCR on which to practice and learn...then we can teach YOU VCR maintenance and repair!

FACT: up to 90% of ALL VCR malfunctions are due to simple MECHANICAL or ELECTRO-MECHANICAL breakdowns!

FACT: over 77 mill on VCRs in use today nationwide! Average VCR needs service or repair every 12 to 18 months!

Viejo's 400 PAGE TRAINING MANUAL (over 500 photos and illustrations) and AWARD-WINNING VIDEO TRAINING TAPE reveals the SECRETS of VCR maintenance and repair. "real-world" information that is NOT available elsewhere!

Also includes all the info you'll need regarding the BUSINESS-SIDE of running a successful service operation!

**FREE INFORMATION**  
CALL TOLL-FREE 1-800-537-0589  
Or write to: Viejo Publications,  
3540 Wilshire Bl., STE 310  
Los Angeles, CA 90010, Dept. EST

Circle (18) on Reply Card

# Heathkit®

A leader in quality electronics for the technically sophisticated customer.

When you need kit or assembled electronic products for work, home or hobby, you can be sure Heathkit products are designed to perform reliably and effectively...year after year.

See what we have to offer. To get your **FREE Heathkit Catalog**, fill out and mail the coupon below or call toll-free today!

**1-800-44-HEATH**  
(1-800-444-3284)

**YES!** Please send me a **FREE** copy of the Heathkit Catalog.

Send To: Heath Company, Dept. 030-824  
Benton Harbor, Michigan 49022

Name \_\_\_\_\_  
Address \_\_\_\_\_ Apt. \_\_\_\_\_  
City \_\_\_\_\_  
State \_\_\_\_\_ Zip \_\_\_\_\_

A subsidiary of Zenith Electronics Corporation CL-801



Powerful Kit Laptop and Desktop Computers



Precision Test Instruments



Dynamic Home Entertainment Products



Skill-Enhancing Educational Courses and Trainers

Circle (19) on Reply Card

# Understanding the VCR vacuum-fluorescent display – Part I

By Stephen J. Miller

Every now and then, one of my customers will come up with a very strange request. A customer called me the other day, convinced the problem with her VCR was a bad tube. She wondered if I would test the tubes and provide replacements. Suppressing a chuckle, I explained that VCRs employ solid-state devices and do not use any tubes. Later, I realized that I had made an error. Most VCRs still contain one tube, the fluorescent display.

## The fluorescent display

Although driven by a digital IC chip, these fluorescent display tubes operate just like any other vacuum tube. That is, if the plate is more positive than the cathode and the cathode-to-grid voltage is less than the cutoff potential, the tube will conduct. Unlike most vacuum tube circuits, fluorescent display tubes either

are biased full on or are completely cut off. Many manufacturers drive the display tube from a high negative voltage supply, which leads to some confusion. However, remember that conduction is controlled by the interelectrode voltage. Even though the tube is driven from a negative supply, the plate is still positive with respect to the cathode during conduction.

The plates of fluorescent displays are commonly called *segments*. Also, the filament serves as the cathode and no separate cathode connection is needed. Figure 1 shows a diagram of a typical display tube. These display tubes can be viewed as numerous individual tubes, all housed in a single glass envelope. Each grid controls a section of the tube. When a grid goes positive, electrons will flow from the cathode to only those segments in the grid that are also positive with respect to the cathode. The electrons, upon striking the segment, will cause it to glow or fluoresce. Very little grid cur-

rent flows because of the large holes in its structure. Most of the electrons continue on past the grid to the segments.

Notice in Figure 1 that the segments are driven from a common bus. This is called a *display matrix* and is used to reduce the number of electrical terminals on both the display tube and the driver IC. A typical display matrix tube can have 15 grids and 9 segments for a total of 26 terminals. If the same display tube were constructed without using such a matrix, a total of 137 terminals would be needed. In a display matrix, each grid section is sequentially activated, one at a time, for a brief instant.

## The grid/segment operation

Figure 2 shows the sequential scanning of the display grids. A particular segment will be illuminated only when both the segment and its grid are positive with respect to the cathode. Because all segments in a given group share a common drive bus, drive signals appear on all segments continuously. However, only those segments whose grid is also positive at that time will be illuminated. The display process operates like this:

1. Segment data for those segments associated with grid section 1 is placed on the segment bus. Grid 1 is then pulled high for several microseconds to illuminate the segments.

2. Grid 1 is pulled low. Segment data for grid section 2 is placed on the bus. Grid 2 is pulled high for several microseconds to allow those segments to illuminate.

3. Grid 2 is pulled low and the process continues for the remaining grids.

After the last grid is serviced, the program loops back and begins again with

Miller is a senior bench technician for a Lancaster, PA, repair company.

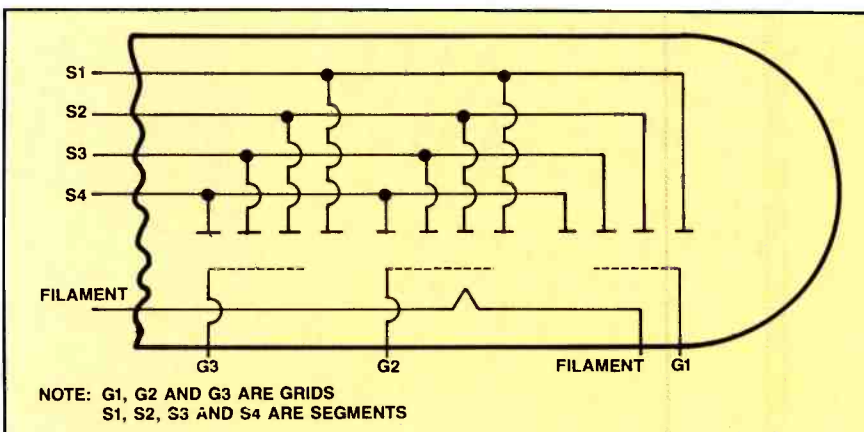

**Figure 1.** The display tubes can be viewed as numerous individual tubes, all housed in a single glass envelope. Each grid controls a section of the tube. When a grid goes positive, electrons will flow from the cathode to only those segments in the grid that are also positive with respect to the cathode. The electrons, upon striking the segment, will cause it to glow or fluoresce.

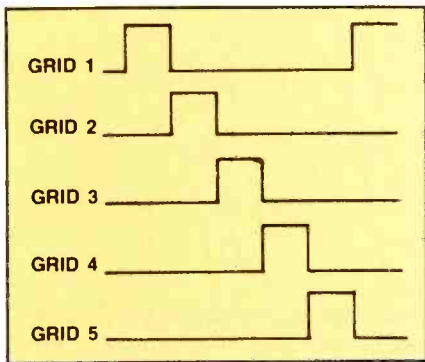

**Figure 2.** In a display matrix, each grid section is sequentially activated, one at a time, for a brief instant. Segment data for those segments associated with the grid section is placed on the segment bus. The grid is pulled high for several microseconds to illuminate the segments. The process repeats for each grid.

grid 1. Because each grid is serviced every few milliseconds, the segments are flashing at a rate of several hundred cycles per second. The human eye blends these rapid pulses together and the display

appears to be continuously illuminated.

### The Bright/Dim switch

Many VCRs allow the user to adjust the relative brightness of the display via a Bright/Dim switch. In the Dim position, this switch instructs the display driver IC to reduce the pulse width of the grid drive signals. When the pulse width is reduced, the segments are on for less time and the display appears dimmer.

It is a common design practice to include both the display and timer microprocessor functions into one IC chip. One function of the microprocessor portion is to monitor the status of the front-panel keys. Because of the large number of front-panel keys, a key matrix is used to reduce the number of key-input terminals to the IC.

Like the display matrix, the key matrix operates by outputting sequentially timed scan pulses. No two scan lines

will output a pulse at the same time. Instead, like spark plugs in an engine, they take turns outputting pulses in a predetermined, orderly fashion. Figure 3 gives an example of a key matrix. The key-input lines form a parallel bus. Each key-scan output line drives a bank or group of keys connected to the input bus. Key scan operates as follows:

1. Scan I output line is pulled high. The input terminals are then monitored for a logic high.
2. Scan I is pulled low and scan II is pulled high. Next, the input terminals are monitored for a logic high.
3. Scan II is pulled low and scan III is pulled high. Again, the input terminals are monitored for a logic high.
4. Scan III is pulled low and the cycle repeats with scan I being pulled high.

Next month, we'll give a specific example of how key scan works, and show some procedures for troubleshooting these circuits. ■



ADMIT ONE

## Your Ticket To SUCCESS

Over 25,000 technicians have gained admittance worldwide as certified professionals. Let your ticket start opening doors for you.

IS CET offers Journeyman certification in Consumer Electronics, Industrial, Medical, Communications, MATV, Radar, Computer, and Video. For more information, contact the International Society of Certified Electronics Technicians, 2708 West Berry St., Fort Worth, TX 76109 • (817) 921-9101

Name \_\_\_\_\_  
Address \_\_\_\_\_  
City \_\_\_\_\_  
State \_\_\_\_\_ Zip \_\_\_\_\_

Send material about IS CET and becoming certified.  
Send one "Study Guide for the Associate Level CET Test." Enclosed is \$10 (includes postage).

## C\$ERVICE® Service Shop Computer Software

A computer software package that is written specifically for the service & repair industry

- Invoicing—T&M Contract/Rentals
- Customer Files
- Technician Efficiency
- Work Ticket Log/Tracking
- Accounts Receivable—Monthly Statements
- Inventory—Shop/Service Vans
- Maintenance History
- Interface to Peachtree Accounting System
- Unique On-Line Support From Our Technical Department

All programs are fully interfaced. Multiple companies, multiple shop locations. Available for IBM & compatibles. Demonstration program available for evaluation.

**America West  
C&E, Inc.**

311 Washburn Drive  
Rock Springs, WY 82901  
307-382-5663

Circle (20) on Reply Card

## PRIME ELECTRONICS CO.

**For All Your Electronic  
Parts & Accessories**

### WE'RE THE ONE . . .

- With over 10,000 Electronic Products
- With Everyday LOW Prices and Volume Discounts
- With 100% Guarantee On All Products
- With the PRB LINE of Replacement Belts and Tires

**For Your Free Copy of Our  
New Catalog Call Toll-Free  
1-800-558-9572**

In Wisconsin 1-800-242-9553  
or for 24 Hour Ordering Call . . .  
FAX: 414-473-4727



**"First in Quality And Service"**

## PRIME ELECTRONICS CO.

P. O. Box 28  
Whitewater, Wisconsin 53190

Circle (21) on Reply Card

# Miniaturizing the IC

The 3-D IC of the future might consist of stacked layers of components, taking up a fraction of the space now required.

Increasing the packaging density of integrated semiconductor components has been accomplished in the past by reducing the structural dimensions. However, recent research conducted by AEG, with the support of the German Ministry of Research and Technology, is investigating the possibility of 3-D

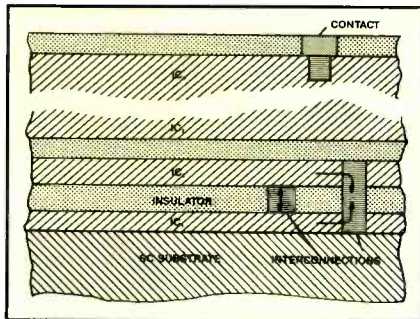

**Figure 1.** A 3-D circuit would consist of stacked component levels, each of which comprises at least one semiconductor layer, with the device levels separated by insulating intermediate layers. Discrete interconnections would run between levels, and electrical access to all component levels would be obtained via contacts on the uppermost level.

ICs, based on the technology of silicon molecular beam epitaxy (Si-MBE) developed in-house several years ago.

### The advantages of three dimensions

A 3-D IC would allow designers to stack components on top of each other, packing the same number of components into one-hundredth of the original chip surface.

A 3-D circuit (see Figure 1) would consist of stacked component levels, each of which comprises at least one semiconductor layer (preferably Si, possibly also III/V semiconductors such as GaAs), with the device levels separated by insulating intermediate layers. The individual devices at each level would be patterned using the same processes as those employed today for 2-D circuits. Discrete interconnections would run between levels, and electrical access to all component levels would be obtained via contacts on the uppermost level.

One benefit of the design is that the

space required for vertical interconnections is much smaller than the more than 50% of the IC surface required for interconnections on planar ICs. The interconnect space could also be reduced by subdividing a circuit into functional blocks and arranging it in layers.

Also, because the majority of the interconnections run vertically between closely packed 3-D levels with spaces only a few micrometers wide, the overall length of the interconnections would be reduced and higher signal speeds could be obtained.

### A new breed of IC

The limiting factors for stacking a large number of 3-D levels are the demands for adequate heat dissipation and low circuit capacitance. The expense of producing the layers is another major limitation. Although the Japanese have been working with increased packaging density for years, the limitations have kept them from achieving a breakthrough.

To reduce the problems created by large numbers of levels, AEG is concentrating on a *multifunctional 3-D system*, in which only two to four component

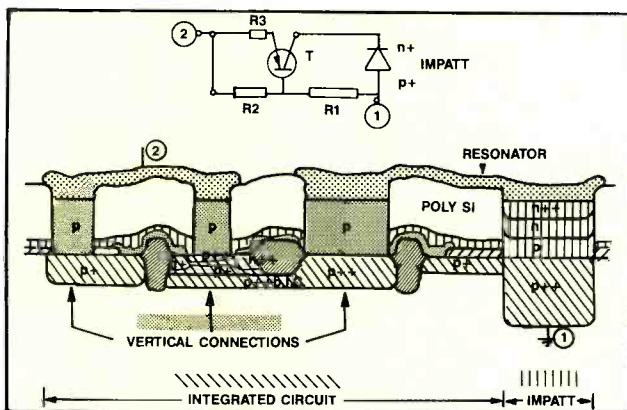

**Figure 2.** With differential molecular beam epitaxy, this type of IC can be manufactured, with a bottom IC layer combined with a second level that accommodates an impact avalanche transit time (IMPATT) active oscillator diode and the necessary vertical interconnections from the first level to the second and third levels. These areas, made of monocrystalline silicon, are electrically insulated from each other by suitably doped polysilicon. The third level would contain passive components.

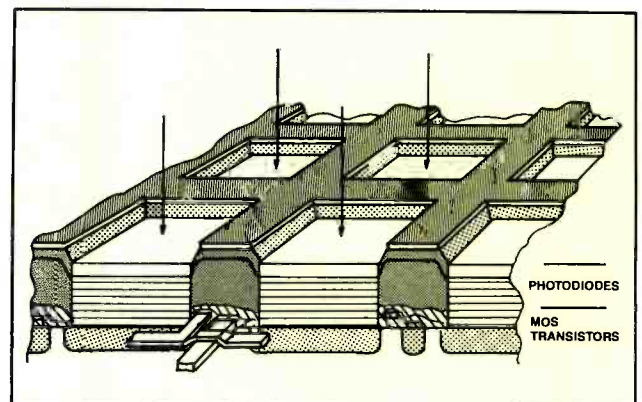
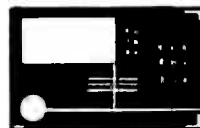

**Figure 3.** With 3-D technology, optoelectronic arrays could have a greater pixel density because the related electronics would be arranged under the optical components.

levels are used. Different types of circuits (analog and digital) or components from different groups of semiconductor materials (Si and GaAs) are combined. The first layer may contain a conventional silicon circuit; the second layer might consist of highly complex multilayer or hetero-structure components; the third might contain suitable passive components. The company might also stack a GaAs IC on top of one made of silicon, separated by a monocrystalline insulating layer, allowing crystallographic adaptation between the different lattice structures of the two semiconductor classes.

Another variety of multifunctional 3-D ICs consists of electronic silicon ICs and optional GaAs devices, permitting the development of compact optoelectronic systems. The properties of each material — the established Si technology and the optoelectronic properties of the GaAs semiconductors — could be exploited.

#### Future technologies

The new devices will depend of the development of new technologies for manufacturing the stacked components made of monocrystalline semiconductors. AEG is concentrating on molecular beam epitaxy (MBE) processes, which allow direct production of monocrystalline semiconductor layers and the manufacture of monocrystalline insulators. With these processes, relatively low temperatures (about 550°C, compared to more than 1,000°C used in present methods) can be used, minimizing thermal damage to other device layers.

If differential MBE (a method of producing monocrystalline semiconductor "islands" for active components in a "sea" of polycrystalline semiconductor material) is used, the company can manufacture something like the silicon monolithic mm-wave IC shown in Fig-

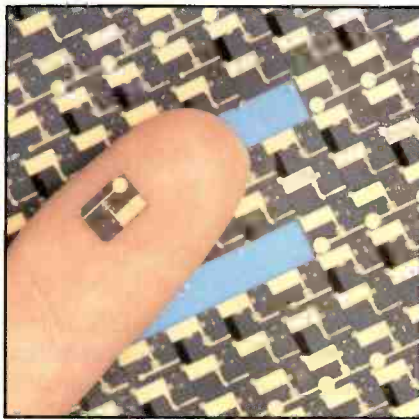

Initial samples of 3-D ICs for the super-high-frequency range, manufactured at the AEG Research Center, consist of three layers, each with complete circuits.

ure 2. A bottom IC layer is combined with a second level that accommodates both the active oscillator diode and the necessary vertical interconnections from the first level to the second and third levels. The diode area and the zones for interconnections, both made of monocrystalline silicon, are electrically insulated from each other by suitably doped polysilicon. The vertical areas could also be dimensioned as resistors, reducing the number of resistors in the first level. The third level would contain passive components.

Because of the shorter interconnections expected in 3-D circuits, high-speed signal processing or rapid access to memory register (such as in digital technology) would benefit from 3-D technology. The increased packaging density would also allow more transistors to be used in the same space. The technology would also be of use in optoelectronic arrays, which could have a greater pixel density, currently limited because of the large number of interconnections in the surface running from the individual pixels to the related electronics, which are usually some distance away. With 3-D technology, the electronics would be arranged under the optical components. (See Figure 3.)

If 3-D ICs are eventually used in electronics, the amount of space necessary on circuit boards would be reduced while the capabilities of the ICs would increase. The result: smaller consumer electronics products with a larger array of special features. ■

## HUGE UNTAPPED MARKET! SERIOUS LACK OF TRAINED TECHNICIANS

LEARN HOW TO  
CLEAN/MAINTAIN/REPAIR  
PRINTERS

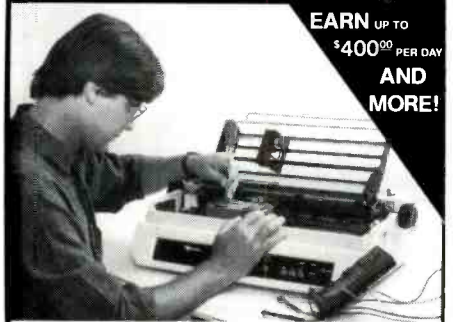

EARN UP TO  
\$400<sup>00</sup> PER DAY  
AND  
MORE!

- Over 32 million personal computers in use nationwide...
- Approximately 85% have a printer attached...
- Average printer needs service every 12 months...
- Vast Majority of printer breakdowns are due to Electro-Mechanical or Mechanical breakdowns—

If you possess average mechanical ability, then we can teach YOU to repair up to 95% of ALL printer malfunctions.

Viejo's award-winning training video reveals the secrets of printer maintenance and repair. Training video covers printer mechanism identification, little known tips, printer circuit fundamentals, advanced diagnosis and repair techniques, and much more! Start repairing printers for profit in days.



200 Page Manual reveals printer maintenance procedures, pricing guidelines, instructions on setting up your workbench, how and where to buy spares, and how to successfully advertise your service business, and much more!

#### TO ORDER:

Please send \$89 per video - all orders with money or order shipped U.P.S. (at no charge to you) the next day. For personal checks please allow 10 days. Make check or money order payable to Viejo Publications.

For more information call 1-800-537-0589

VIEJO PUBLICATIONS, INC.

3540 Wilshire Blvd., Ste. 310, Dept. P1, Los Angeles, CA 90010  
California residents please add 6.5% sales tax.

Circle (22) on Reply Card

## ATTENTION TECHNICIANS

- ★ JOB OPENINGS
- ★ MONTHLY TECHNICAL TRAINING PROGRAM
- ★ BUSINESS MANAGEMENT TRAINING
- ★ SDC SATELLITE NEWS
- ★ CERTIFICATION
- ★ TECHNICAL SEMINARS

All of this in a nonprofit international association for technicians

FIND OUT MORE:



604 N. Jackson St.  
Greencastle, IN 46135  
1-800-359-6706

# The basics of Yellow Page advertising

By William J. Lynott

If you want to liven up a group of electronics servicers with small businesses, mention Yellow Pages.

It's a rare service entrepreneur who doesn't have strong feelings on this controversial topic. And with good reason. For most service dealers, YP advertising takes up a big chunk of the advertising budget; for many, it's the entire advertising budget. That alone is enough to make it controversial.

But today's level of controversy goes far beyond the obvious. The proliferation of YP directories in most locations, and the increasing number of ad categories in each book, has turned YP advertising into a king-sized headache for the typical electronics servicer. It is essential that you take steps to ensure that every dollar you spend on YP ads is profitably invested.

Unfortunately, a lot of hard-earned money is wasted on poorly conceived YP ads. A look at the telephone directory of almost any city will provide a quick education on what not to do in your YP ads. Here are a few of the basic requirements that are most often overlooked.

- *Monitor the results of your YP ads.* Too many servicers overestimate the amount of business brought in by their YP advertising. There is a close relationship between the effectiveness of your ads and the share of your budget that should be allotted to them. The only way to determine whether your advertising is paying off is to monitor it. (See the September Business Corner for more information on business percentages you can aim for.)

- *Include the essential information in your ad.* Many YP ads for service companies are cluttered with art work and wording that doesn't help sell the service offered. Industry studies indicate

that the most successful ads include information that the customer needs: your location, business hours, the products or brands you service. (However, you should be careful to avoid cluttering up your ad with endless lists of brand names. If you service most major brands, just say so. If you specialize in only a few brand names, feature them prominently.)

- *Tell the customer what you do.* People who look at Yellow Page ads for service already know what service they need. Your ad should prominently announce the type of service you offer. Your company name should *not* be the largest headline in your ad (unless yours is a household name like Sears or General Electric). You have less than a second to catch and retain your prospect's eye. That's why every YP ad must be a "grabber": It must feature something that relates to the prospect's need.

- *Tell your prospective customers why they should do business with you.* Every one of your ads should contain something that separates your ad from the rest of the ads that clutter up every page. If you specialize in a certain brand name or category of product, feature that information prominently. If you provide same-day service or some other advantage, grab your prospect with that information. Any information that doesn't tell the prospect how or why to do business with you is wasting valuable advertising space.

- *Pick the size of your ad carefully.* According to the highly regarded Yellow Pages Report (Consumer Review Systems, St. Paul, MN), picking the largest possible size ad is not necessarily the most effective way to spend advertising dollars. Although the largest ads tend to catch the eye first, they often are not the ones selected by the prospect. An ad that is large enough to catch the eye and contains the proper content is by far the most potent combination. Spending large amounts of money merely to be the

largest ad on the page is usually a losing proposition. Make certain your ad tells the facts the prospect needs to know, and be sure the content of the ad addresses the prospect's needs. That's the best way to enhance the effectiveness of your YP advertising budget.

- *Think before you invest in color.* Here's a surprise: Including a second color in your YP ad (usually red ink) does not necessarily increase its effectiveness. In fact, according to Yellow Pages Report, "the use of red ink with very large ads (3/16-page and larger) actually decreases the possibility of selection."

For smaller ads, however, the situation reverses. According to the report, the use of red ink in 1/16-page ads does increase the likelihood that the ad will be selected by a prospect.

- *Never lose sight of the fact that your YP representative is primarily a salesperson.* No matter how knowledgeable, friendly or helpful, he earns commission, and his livelihood depends on increasing revenues from his accounts. Although the advice you get from a YP ad sales representative may be technically correct, it may not necessarily be the best advice for your situation.

Being knowledgeable about YP advertising is your responsibility. If you forfeit that responsibility to someone else, particularly a salesperson for the product itself, you can expect to be at a disadvantage.

Chances are, Yellow Pages advertising will be an important part of your life as long as you are involved in the service business. It makes good sense to keep yourself as up-to-date and knowledgeable about that part of your business as with any other.

**Editor's note:** For information on the Yellow Pages Report, contact Consumer Review Systems, 905 Raymond Ave., St. Paul, MN 55114. ■

---

Lynott is president of W.J. Lynott, Associates, a management consulting firm specializing in profitable service management and customer satisfaction research.



# Readers' Exchange

Readers' Exchange items cost 50 cents per word, per insertion, and must be accompanied by payment to ensure publication.

- Each initial or abbreviation counts as a full word (w/probes would be two words).
- Model numbers count as one word only. Company names also count (ACME model xyz would be three words).
- Specification ranges count as one word (1Hz-3MHz).
- Addresses should be included in the word count.
- Readers' Exchange items will continue to cover only Wanted and For Sale items. Specialized heads, such as job opportunities, business opportunities or help wanted, must continue to run in the Classifieds section.

Send your Readers' Exchange submissions, with check or money order, to:

**READERS' EXCHANGE**  
c/o Susan Edwards  
Electronic Servicing & Technology  
P.O. Box 12901  
Overland Park, KS 66212

## FOR SALE

Magnavox factory service data, 1966 thru 1987, good condition. \$600 *George W. Crouch 4018 Lillian Dr. Concord, CA 94521 Phone (415)682-8841* 10-89 1-T

Retiring: All TV Shop Equipment and Parts. *Stettler TV, 9451 Banning Ave. HUNTINGTON BEACH, CA 92646 (714) 963-4379* 10-89 1-T

Scencore equipment: CG22 Caddy Bar Jr., VA62 video analyzer, SG165 AM/FM stereo analyzer, VCR test jig, SC61 waveform analyzer; Leader Lcg 396 NTSC pattern generator; Beltron 8080A CRT power supply; two B&K 707 tube testers; RCA isolation transformer. Also have large parts inventory of RCA, Zenith, Magnavox, Sylvania, Quasar, GE and ECG transistor stock—send \$1 and a SASE for list. *Carl F. Haupt, 4546 W. 8300 North, American Fork, UT 84003; 801-756-6612.* 10-89 1-T

Scencore FE-21 multimeter, Scencore YF333 Ringer Yoke & Flyback Tester, Sprague Capacitor Analyser Model #TO-6A, \$100.00 each or best offer (213) 292-0340 *John Warren.* 10-89 1-T

SAM'S PHOTOFACTS. #1000-1500 \$2.50 ea. #1501-2000 \$3.00 ea. PLUS SHIPPING. LARGE LIST OF TEST EQUIPMENT. SASE. PHILCO PREDICTA \$300. *WALTER J. FROEHLICH P. O. BOX 271 WESTFIELD, N.J. 07091 201-232-3867* 10-89 1-T

Sams Photofacts #800-1799 1,000.00 or Best offer. Add shipping. *Calvin Boddie, 660E. Yucca St. Oxnard, CA 93030 (805) 487-7732 after 4:00 P.M.* 10-89 1-T

Scencore—full line of equipment for TV-VCR-Stereo service at 40% -50% off. Deepest discount for all to one address. Near new (pur 7/87-01/89) includes all leads, manuals, supplied accessories and most Tech Tips & optional accessories. TF46/39G85. DVM56A/DBA220/TP222/CS223/TP225/CC237. PR57. SC61/PL207/DP226/NP229 (2ea)/39G81. VA62/TP212/TP225/EX231. VC63, NT64, ST65, SR68, CR70/39G170. FC71/AN210/BY234/CC238. LC75/FC221/SCR250, SG165. Lv msg or send SASE. *R. Bishop, General Delivery, Tiller, OR 97484; 503-825-3970.* 10-89 1-T

Heath IGB-102 RF Sig. gen. 100kHz-110MHz w/probe & manual \$25, Heath IG-52 TV, sweep gen, probe, manual \$35, B&K Precision E200 gen 88kHz-120MHz w/manual \$35, B&K 1077 spot scanner TV analyst w/test \$75. 2 new BC-645A transceiver 420-450MHz, w/conversion instructions \$75 ea. Polarad IC-120 microwave impulse gen. 1MHz-10GHz \$50. Polarad P-3 power meter 10-40,000 MHz (meter sticks)\$40. 2 HP 400D VTVM \$25 ea. HP 400H VTVM \$40. HP 410B VTVM (no imp. conn., or manual) \$35. Boonton 91-D RF VTVM 20 kHz-1.2GHz (no probe or manual) \$50. Most like new & calibrated. Add UPS & COD. *Chuck Vaccaro, 708 Booth Lane, Ambler, PA 19002 (215) 646-3641.* 10-89 1-T

CRT Equipment for sale. Five years old. Best offer. *815-965-6668* 10-89 1-T

Gould K-25 General Purpose Logic Analyzer with cables and manual still in box new. \$1850.00 *Raymond McLaughlin, URI 120 Crawford Hall, Kingston, R.I. 02881 401-792-2748* 10-89 2-T

## Classified

Advertising rates in the Classified Section are \$1.65 per word, per insertion, and must be accompanied by payment to insure publication.

Each initial or abbreviation counts as a full word.

Minimum classified charge \$35.00.

For ads on which replies are sent to us for forwarding (blind ads), there is an additional charge of \$40.00 per insertion to cover department number, processing of replies, and mailing costs.

Classified columns are not open to advertising of any products regularly produced by manufacturers unless used and no longer owned by the manufacturer or distributor.

## BUSINESS OPPORTUNITIES

**VCR SERVICE COMPANY** in beautiful Monterey, CA. \$40,000-\$50,000 yearly sales. \$25,000 in parts, equipment, furniture and fixtures. Using only 400 square feet of 2,200 square feet. Busy drive-by corner building. Lease/rent—Only \$675/mo. for entire facility. Lots of room to expand at no extra rent cost. Illness forces give away sale price of only \$39,500. Hurry! Won't last. 408-649-6036. 10-89-3T

**BE YOUR OWN BOSS**—Audio/Video/TVRO sales and service. Perfect small business for 1-2 man operation. Profitable Colorado business. Low overhead, owner can finance. 303-867-3554. 9-89-2T

**TV SERVICE SHOP:** Beautiful Oregon coast, equip with latest Scencore service equipment. Only service shop in 50 mile radius. Gross 100,000 yearly sales. \$95,000 send inquires to: 2205 10th, Florence, OR 97439. 10-89-1T

**ROCHESTER, NEW YORK, ESTABLISHED 1955,** owner retiring, will train, 2 way, auto sound, telephones, sales, service; building, 2 bays. (716) 654-8370. 9-89-2T

**LARGE AUDIO/VIDEO SERVICE BUSINESS.** In sunny S.W. city. Established 20 yrs. Well-equipped. Price & terms negotiable. (602) 298-8827. eves. 8-89-tfn

## FOR SALE

VHS-VCR Repair Solutions Sets I, II, III, IV, V. Each contains 150 symptoms and cures, cross reference chart, free assistance, \$11.95 each, all five \$49.95. Eagle Electronics, 52053 Locks Lane, Granger, IN 46530. 10-89-TFN

**TV/VCR TUFF TIPS** listed by mfg. & model. Over 400 tips. \$21.95. TV Tips only \$11.95, VCR Tips only \$13.95. **VCR CROSS-REFERENCE** listing for electronically similar manufacturers, RCA, GE, Sylvania, Panasonic, Quasar, Magnavox, Philco, & J.C. Penney, \$19.95. **TV/VCR FAILURE HISTORIES**, Multiple cures for most problem areas. Send \$7.95 with mfg. and model number. Money will be refunded with free sample if model is not on database. Add \$1.50 postage and handling. **TECH CURES**, 4825 Fredericksburg Road, San Antonio, Texas 78229. 12-88-TFN

**COMPUTER TV/VCR REPAIR TIPS DATABASE PROGRAM** IBM Compatible w/hard drive). Scan symptoms and cures by model and chassis. Add, change, delete, print out. Includes database with over 1,000 up-to-date repair tips. \$69.95 plus \$2.50 postage and handling. Computer Assistance, Box 232026, Anchorage, AK 99523. 8-89-3T

**TV/VCR REPAIR TIPS VOLUMES I AND II.** Each with 1,000 up-to-date problems/cures listed by model and chassis for quick easy lookup. \$29.95 per volume. Add \$2.50 postage and handling. Computer Assistance, Box 232026, Anchorage, AK 99523. 8-89-3T

**TV SCHEMATICS FOR SALE**, 702 sets of SAMS Photofacts, JAN 73 through JUNE 81. Most are new unused. Best offer. S. Bennett, RDI, Middlebury, VT 05753. TEL: 802-388-7228 after 6 pm. 10-89-1T

**TV TROUBLESHOOTING:** Over 300 problems/solutions. Nothing old listed. \$12.00, add \$1.50 shipping. Refund if not satisfied. Jones Enterprises, Box 702, Niceville, FL 32578. 6-89-tfn

**CRT EQUIPMENT** for sale. 5 years old. Best offer. 815-965-6668. 10-89-1T

Phone  
**Renée Hambleton**  
for  
Classified Advertising  
Information  
**(913) 888-4664**

**BUYING AND SELLING** late model Electronic Test Equipment. Tektronix, HP, Fluke, Wavetek, etc. O'scopes, Signal Gen's, Pwr. Supplies, etc. Cal-Scope, 473-707 Macara Ave., Sunnyvale, CA 94086. (408) 730-4573. 8-89-3T

**INTEGRATED CIRCUITS**—Lowest prices on Admiral, GE, NAP, Philco, RCA, Sears, Sylvania and Zenith types. Write PEC, Box 894, Union, N.J. 07083. 8-89-4T

**TV TOUGH DOGS:** 300 symptoms and cures. Send \$8.95 to DAVIS TV, 11772 Old Fashion Way, Garden Grove, CA 92640. 10-87-tfn

**PHOTOFACTS:** Folders under #1400, \$4.00. Above #1400, \$6.00. Sent same day first-class postpaid. Loeb, 414 Chestnut Lane, East Meadow, NY 11554. 9-89-3T

**REDUCED 75%**, Diehl Mark V scanner \$249, Diehl Mark III scanner \$99. New. 2805 University Ave., Madison, Wis. 53705. 608-238-4629, 608-233-9741. 3-89-tfn

## SERVICES

**SPEAKER REPAIR**, 4"-18" Speakers reconed. Cross-over parts. Orban Audio, 119 7th St. NW, North Canton, Ohio 44720, (216) 497-9932 6pm-9pm EST. 4-89-tfn

# FIX VCR's

3 out of 4 VCR breakdowns are due to a mechanical problems.

Do you have the tools to find these problems?

TENDEL Does!



Call Toll Free

**(800)538-6894**

In Calif- (916)939-4005

**4475 Golden Foothill Pkwy  
El Dorado Hills, CA 95630**

Circle (23) on Reply Card



## "Tech's Guide To Pricing"

updated new 5th edition... a framework for setting rates that apply to Hi-Tech products... a formula that guarantees SUCCESS!

Call Toll Free for details 8/5  
**1-800-228-4338 CST**

Circle (24) on Reply Card

### WHY PAY SENCORE \$1295?

TEST/CLEAN/RESTORE with a UNIVERSAL CRT ADAPTER that fits all CRT testers and quickly hooks-up to all CRT's on the market (now or in the future). Guarantees profit & total CRT servicing. Used by TV Repair, US Govt., Airlines, Computer Serv., Dept. of Defense. Patented Adaptor-Sockets-CRT Reference/Setup book—Only \$59.95 plus \$2.50 postage & handling. Our 6th year. Over 15,000 sold. Chargecards/Checks/COD. Money Back Guarantee.

**FREE CALL 1-800-331-9658**  
**DANDY MFG. CO./RANDALL ELECTRONICS**  
(918) 682-4286, 2323 Gibson St., Muskogee, OK 74403

Circle (25) on Reply Card

## IN OUR CONTINUING EFFORTS TO SERVE YOU...

From time to time, Intertec Publishing Corp. makes its subscriber lists available to carefully screened companies or organizations whose products, services, or information may be of interest to you. In every case, list users must submit their promotional material for approval. They may use the list only once.

No information other than name and address is ever divulged, although names may be selected by segments to which the particular offer might appeal.

We are confident that the majority of our readers appreciate this controlled use of mailing lists. A few people may prefer their names not be used.

If you wish to have your name removed from any lists that we make available to others, please send your request, together with your mailing address label to:

**Direct Mail Mgr.  
Intertec Publishing Corp.  
P.O. Box 12901  
Overland Park, KS 66212**

# Advertisers' Index

Company	Pages Number	Reader Service Number	Advertiser Hotline
America West C&E, Inc.	55	20	307/382-5663
Amprobe Instruments	1	3	516/593-5600
B.M.I., Inc.	39	26	800/876-5355
Chemtronics, Inc.	23	12	800/645-5244
Cleveland Institute of Electronics	8A-8B,9	8	800/321-2155
Dandy Mfg. Co.	60	25	800/331-9658
ETA	57		800/359-6706
Fluke, John Mfg. Co., Inc.	5	6	800/227-3800
Fordham Radio Supply Co.	17	10	800/645-9518
Heath Co.	53	19	800/444-3284
Iscet	55		817/921-9101
Leader Instruments Corp.	3	4,5	800/645-5104
Matsushita Services Co. (Publication Div.)	43	14	201/392-4281
MCM Electronics	49	16	800/543-4330
Nesda	49,51		817/921-9061
NRI Schools-Electronics Division	15		
Nutronix Inc.	51	17	313/939-4710
Paladin Corporation	IBC	2	805/499-0318
Panavise Products Inc.	47	27	213/595-7621
Parts Express Int'l. Inc.	37	15	513/222-0173
Philips ECG	7	28-31	800/225-8326
Prime Electronics	55	21	414/473-4727
PTS Corp	41	13	800/333-PTSI
Sencore, Inc.	IFC	1	800/843-3338
Sperry Tech, Inc.	60	24	800/228-4338
Tentel	60	23	800/538-6894
U.S. Instrument Rentals	19	11	800/824-2873
Viejo Publications	55-57	18,22	800/537-0589
Windsor Technologies, Inc.	13	9	415/456-2209
Zenith	BAC		

## ADVERTISING SALES OFFICES

### ELECTRONIC

Service & Technology

#### KANSAS CITY, MISSOURI

Greg Garrison, Sales Manager  
P.O. Box 12901  
Overland Park, KS 66212  
Phone: (913) 888-4664  
Fax: (913) 541-6697  
Telex: 42-4156 INTERTEC OLPK

#### OXFORD, ENGLAND

Nicholas McGeachin  
Roseleigh House, New Street  
Deddington, Oxford OX5 4SP  
Phone: (0869) 38794  
Telefax: (0869) 38040  
Telex: 837469 BES G

#### TOKYO, JAPAN

Mashy Yoshikawa  
Orient Echo, Inc.  
1101 Grand Maison  
Shimomiyabi-Cho, 2-18  
Shinjuku-ku, Tokyo 162, Japan  
Tel: 03-235-5961  
Telex: J-33376 MYORIENT

#### FREWVILLE, SOUTH AUSTRALIA

John Williamson  
Hastwell, Williamson, Rep. Pty. Ltd.  
109 Conyngham Street  
Frewville 5063  
South Australia  
Phone: (08) 79 9522  
Fax: 08 79 9735  
Telex: AA87113 HANDM

# Hand Tools With Horsepower!



# PALADIN

## That's the name of the game

When you play for keeps, win the game with hand tool horsepower from Paladin.

Whether your game is production, installation or maintenance of connection systems for power and information, Paladin has your tool. Get the job done faster and better, and outshine the others with professional results every time.

After more than ten years serving the electronic, electrical, telecommunications and related industries, we understand your specialized needs, and have precision-engineered and patented solutions for almost any application you can imagine.

### There's only one move to make...

You've checked the others. Now make your move to Paladin for cable



Send for our free, 152-page full-color catalog.



**PALADIN**

At work with professionals every day™

**PALADIN CORPORATION**

3543 Old Conejo Road, Suite 102

Newbury Park, CA 91320

(805) 499-0318 - FAX (805) 499-4006

A member of the Weidmüller group of companies

Circle (2) on Reply Card

preparation tools, strippers, crimpers and cutters, slitters, notchers, and screwdrivers, plus accessories like connectors, telecom hardware and other essential service and production aids. If we don't sell it yet, we can probably make it for you!

Paladin tools do more than fit your application. They also fit your hand, and your demands for ergonomic design, ease of use, and safety. With Paladin on your team, you'll win the time-and-money game, too... hands down.

Send for our free, 152-page full-color catalog, or call today for a demonstration at your workplace or your nearest Paladin distributor. You'll see for yourself that when you play the game with Paladin, you're a winner every time!

# PLAY IT SMART!



**INSIST ON  
GENUINE ZENITH  
FACTORY-FRESH  
REPLACEMENT PARTS  
NOW AVAILABLE AT  
AUTHORIZED  
EXCHANGE COUNTERS  
THROUGHOUT THE U.S.**

Two of the most important reasons for exchanging Zenith replacement parts through your participating distributor's Exchange Program:

- 1) Your replacement part will most likely contain the latest Zenith engineering updates,
- 2) You will be assured of receiving a factory-fresh replacement part remanufactured and serviced for reliability by Zenith people

as knowledgeable and dedicated as those who made the original.

Don't risk exchanging sophisticated Zenith modules, tuners, channel selectors and sub-assemblies anywhere else.

Write today and we'll help you locate an authorized distributor Exchange Counter near you!

**ZENITH**  
®

*The quality goes in before the name goes on.®*

Zenith Service, Parts & Accessories/11000 Seymour Avenue/Franklin Park, IL 60131 • A Division of Zenith Electronics Corporation